



PREMIUM ELECTRIC OUTBOARD MOTORS



The New
HELMSMAN system
Available Now!

- MODERN
- SAFETY
- CLEAN
- SIMPLE
- HIGH-TECH
- POWERFUL
- PREMIUM

2019-2020 CATALOGUE

MODEL: OSAPIAN

50701
12V-30Lbs

50702
12V-40Lbs

50703
12V-55Lbs



图片与实物略有不同!
Actual model may vary from image!



SPECIFICATIONS

MODEL: 产品型号:
50701 / 50702 / 50703

Power of thrust: 峰值推力:
30Lbs / 40Lbs / 55Lbs

Max Voltage: 电压:
DC 12V (All)

Power - Max: 功率:
360W / 500W / 600W

Amp - Max: 电流:
30A / 42A / 50A

Depth Adjustment: 深度调节:
Depth Collar (All)

Prop Type: 螺旋桨型号:
2 blade prop 9inch diam (50701,50702)
3 blade prop 9.3inch diam (50703)

Prop Speed at Full Power: 转速:
Max. 1200 / 1380 / 1250 rpm underwater

Battery Type Required: 电池要求:
1x105AH deep cycle (All)

Steering: 转向操控:
360 degree control (All)

Decibel Level (db): 噪音等级:
50db (All)

Weight (N.W.): 重量:
6.6kg / 7.1 kg / 8.6kg

Shaft Type: 主杆类型:
Cast Aluminium (All)

Shaft Length: 主杆长度:
800mm / 900mm / 900mm

Colour: 颜色:
Black (All)

Max Boat Length (Suggestion): 船长:
4m / 4.7m / 5.5m



The Osapian range features durable 12 volt motors and available in 30, 40 and 55Lbs models. Osapian motors are equipped with 5 forward and 3 reverse positions. Osapian models are light-weight (from 6.6kg), easily portable and very compact thanks to the collapsible steering lever.

The depth height can easily be adjusted, so you can motor in virtually any water. The steering lever adjusts to different angles, is telescopic and extendable for comfortable control. The Osapian models also features an LED battery level indicator. Suitable for both salt and fresh water.

MODEL: OSAPIAN F

50708
12V-30Lbs

50714
12V-40Lbs

50716
12V-55Lbs



前进/后退档位调速
Multi-Speed F/R

DD Brush Motor
有刷直驱电机

图片与实物略有不同!
Actual model may vary from image!



SPECIFICATIONS

MODEL: 产品型号:
50708 / 50714 / 50716

Power of thrust: 峰值推力:
30Lbs / 40Lbs / 55Lbs

Max Voltage: 电压:
DC 12V (All)

Power - Max: 功率:
360W / 500W / 600W

Amp - Max: 电流:
30A / 42A / 50A

Depth Adjustment: 深度调节:
Depth Collar (All)

Prop Type: 螺旋桨型号:
2 blade prop 9inch diam (50708,50714)
3 blade prop 9.3inch diam (50716)

Prop Speed at Full Power: 转速:
Max. 1200 / 1380 / 1250 rpm underwater

Battery Type Required: 电池要求:
1x105AH deep cycle (All)

Steering: 转向操控:
360 degree control (All)

Decibel Level (db): 噪音等级:
50db (All)

Weight (N.W.): 重量:
6.3kg / 6.9 kg / 8.4kg

Shaft Type: 主杆类型:
Cast Aluminium (All)

Shaft Length: 主杆长度:
800mm / 900mm / 900mm

Colour: 颜色:
Black (All)

Max Boat Length (Suggestion): 船长:
4m / 4.7m / 5.5m



Offer 10 levels of tilting position.



Provide 5-speed levels of forward and 3-speed levels of reverse control.



350mm length of handle extension.



Display 3 levels of battery power.

The Osapian F range features durable 12 volt motors and available in 30, 40 and 55lbs models. Osapian F motors are equipped with 5 forward and 3 reverse positions. Osapian F models are light-weight (from 6.3kg).

The depth height can easily be adjusted, so you can motor in virtually any water. The steering lever adjusts to different angles, is telescopic and extendable for comfortable control. The Osapian F models also features an LED battery level indicator. Suitable for both salt and fresh water.

MODEL: W20

50735
12V-20Lbs



前进/后退档位调速
Multi-Speed F/R

DD Brush Motor
有刷直驱电机

图片与实物略有不同!
Actual model may vary from image!

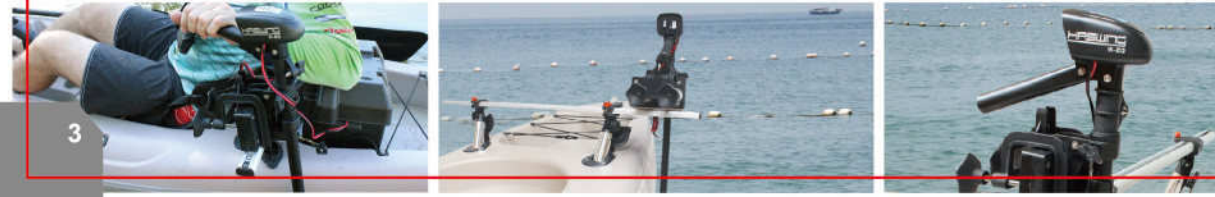

SPECIFICATIONS

MODEL: 产品型号:
50735

Power of thrust: 峰值推力:
20Lbs

Max Voltage: 电压:
DC 12V

Power - Max: 功率:
200W

Amp - Max: 电流:
17A

Depth Adjustment: 深度调节:
Depth Collar

Prop Type: 螺旋桨型号:
2 blade prop / 5.9inch diam

Prop Speed at Full Power: 转速:
Max.1200 rpm underwater

Battery Type Required: 电池要求:
1x20AH Deep Cycle

Steering: 转向操控:
360 degree control

Decibel Level (db): 噪音等级:
≤50db

Weight (N.W.): 重量:
2.3kg

Shaft Type: 主杆类型:
Cast Aluminium

Shaft Length: 主杆长度:
600mm

Colour: 颜色:
Black

Max Boat Length (Suggestion): 船长:
3m



The W20 range features durable 12 volt motor and available in 20Lbs models. W20 motor are equipped with 2 forward and 2 reverse positions. W20 model are light-weight (from 2.3kg), easily portable and very compact thanks to the collapsible steering lever.

The depth height can easily be adjusted, so you can motor in virtually any water. The steering lever adjusts to different angles. The W20 model also features an LED battery level indicator. Suitable for both salt and fresh water.

MODEL: CAYMAN B

50700
12V-55Lbs

50718D
24V-80Lbs

遥控系列 / Remote Control Series

Wireless Remote Controller (50802) Included! 433MHz

单向无级调速
One-Way Stepless Speed



3 Quick Retract Bracket

2 Depth Collar

6 Durable Motor

5 Anti-impact propeller

DD Brush Motor
有刷直驱电机

Wired Foot Controller (50800) For Option! Not Included!

SPECIFICATIONS

MODEL: 产品型号:
50700 / 50718D

Power of thrust: 峰值推力:
55Lbs / 80Lbs

Max Voltage: 电压:
DC 12V / 24V

Power - Max: 功率:
600W / 1080W

Amp - Max: 电流:
50A / 45A

Depth Adjustment: 深度调节:
Depth collar (All)

Prop Type: 螺旋桨型号:
3blade prop / 9.3inch diam (50700)
2blade prop / 11.4inch diam (50718D)

Prop Speed at Full Power: 转速:
Max. 1250 rpm underwater (50700)
Max. 1500 rpm underwater (50718D)

Battery Type Required: 电池要求:
1 x105AH Deep Cycle (50700)
2 x105AH Deep Cycle (50718D)

Steering: 转向操控:
360 degree control (All)

Decibel Level (db): 噪音等级:
50db (All)

Weight (N.W.): 重量:
13.7kg / 17.5kg

Shaft Type: 主杆类型:
Cast Aluminium (All)

Shaft Length: 主杆长度:
1370mm / 1490mm

Colour: 颜色:
Black (All)

Max Boat Length (Suggestion): 船长:
5.5m / 6.5m

RETRACTABLE
推进器收放踏板
Press it to deploy or stow the motor easily.

50802 REMOTE CONTROLLER
无线遥控器
Function: On/Off, Speed Up/Down, Full Speed, Turn Left/Right, Pairing.

Not Included! WIRED FOOT CONTROLLER
线控脚踏控制器 (选配)
LCD Display; Function: On/Off, Speed Up/Down, Full Speed, Turn Left/Right.

MOTOR FIN
独立鳍翼设计
Separated design for propeller protection.

POWER DISPLAY
电源显示
Display 5 levels of battery power.

图片与实物略有不同!
Actual model may vary from image!

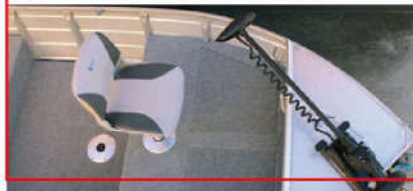

The Cayman B Bow Mount Trolling Motor aimed at serious fishermen who require the versatility of guiding their motor via a wireless hand remote or wired foot control pedal. This feature packed bow mount trolling motor comes standard with a wireless hand control, sacrificial anode and encapsulated electronics. Supplied standard with all the necessary stainless steel nuts and bolts to fit straight onto the boat, or option up with our quick release plate with a foot print of just 120mm x 200mm when not in use. All motors feature LED battery meters. Upgraded packages are available which include the wired foot controller and quick release mounting plate. Suitable for both salt and fresh water.

MODEL: OSAPIAN

50727
24V-80Lbs

With
Gear Box

50755
24V-80Lbs

SPECIFICATIONS

MODEL: 产品型号:
50727 / 50755

Power of thrust: 峰值推力:
80Lbs (All)

Max Voltage: 电压:
DC 24V (All)

Power - Max: 功率:
840W / 1080W

Amp - Max: 电流:
35A / 45A

Depth Adjustment: 深度调节:
Depth Collar (All)

Prop Type: 螺旋桨型号:
3blade prop / 11.8inch diam (50727)
2blade prop / 11.4inch diam (50755)

Prop Speed at Full Power: 转速:
Max. 890 rpm underwater (50727)
Max. 1500 rpm underwater (50755)

Battery Type Required: 电池要求:
2x105AH Deep Cycle (All)

Steering: 转向操控:
360 degree control (All)

Decibel Level (db): 噪音等级:
60db / 50db

Weight (N.W.): 重量:
12.2kg / 13.5kg

Shaft Type: 主杆类型:
Cast Aluminium (All)

Shaft Length: 主杆长度:
1000mm (All)

Colour: 颜色:
Black (All)

Max Boat Length (Suggestion): 船长:
6.5m (All)



TILTING THE MOTOR
角度调节支架

Offer 7 levels of
tilting position.



FOLDING HANDLE
手柄角度调节

Angle of the handle
can adjust 0 to 110
degrees.



SPEED CONTROL
推进变速调节

Provide 5-speed
levels of forward
and 3-speed levels
of reverse control.



TELESCOPING
伸缩性操纵手柄

350mm length of
handle extension.



POWER DISPLAY
电源显示

Display 5 levels of
battery power.



50727
Brush Motor
With Gear Box
有刷齿轮箱变速电机

50755
DD Brush Motor
有刷直驱电机

图片与实物略有不同!
Actual model may vary from image!



The Osapian range features durable 24 volt motors and available in 80Lbs models. Osapian motors are equipped with 5 forward and 3 reverse positions. Osapian models are very compact thanks to the collapsible steering lever.

The depth height can easily be adjusted, so you can motor in virtually any water. The steering lever adjusts to different angles, is telescopic and extendable for comfortable control. The Osapian models also features an LED battery level indicator. Suitable for both salt and fresh water.

MODEL: **COMAX N**

50717 / With Motor up & Down System
12V-55Lbs

SPECIFICATIONS

MODEL: 产品型号:
50717

Power of thrust: 峰值推力:
55Lbs

Max Voltage: 电压:
DC 12V

Power - Max: 功率:
660W

Amp - Max: 电流:
55A

Depth Adjustment: 深度调节:
Electric Trim System

Prop Type: 螺旋桨型号:
3 blade prop / 9.3inch diam

Prop Speed at Full Power: 转速:
Max.1200 rpm underwater

Battery Type Required: 电池要求:
1 x105AH Deep Cycle

Steering: 转向操控:
90 degree control

Decibel Level (db): 噪音等级:
50db

Weight (N.W.): 重量:
14.5kg

Shaft Type: 主杆类型:
Stainless steel

Shaft Length: 主杆长度:
Variable

Max Boat Length (Suggestion): 船长:
5.5m



1 Emergency stop switch
Power switch

2:1 Steering 2

3 Stepless Speed Control Handle
(Forward/Reverse)

4 Foldable Handle

前进/后退无级调速
Stepless Speed F/R

5 Bracket

电动升降调节
Electric Depth
Adjustment

265

6

Included

Power switch/Emergency stop switch

7 Durable Motor

Brush Motor

有刷电机

图片与实物略有不同!
Actual model may vary from image!



The Comax N electric trolling motor range specifically designed for electric only waterways features a durable 12 volt 55lbs motor and integrated electric trim system, innovative 2:1 steering system and telescopic steering lever. Comax N motors are equipped with a step-less digital speed controller which provides precise power control, ideal for trolling at the optimum speed. The Comax N also features an LED battery level indicator. Suitable for both salt and fresh water.

MODEL: CAYMAN B

50739
12V-55Lbs

50742
24V-80Lbs

50743
36V-101Lbs

遥控系列 / Remote Control Series

Wireless Remote Controller
(50802N) Included! **1**

2.4 GHz

单向无级调速
One-Way Stepless Speed



3 Quick Retract Bracket

Depth Collar **2**

Wireless Foot Remote Controller
(50805N) For Option! **4**
Not Included!

Durable Motor **6**

5 Anti-impact propeller

DD Brush Motor
有刷直驱电机

图片与实物略有不同!
Actual model may vary from image!



SPECIFICATIONS

MODEL: 产品型号:

50739 / 50742 / 50743

Power of thrust: 峰值推力:

55Lbs / 80Lbs / 101Lbs

Max Voltage: 电压:

DC 12V / 24V / 36V

Power - Max: 功率:

600W / 1080W / 1620W

Amp - Max: 电流:

50A / 45A / 45A

Depth Adjustment: 深度调节:

Depth collar (All)

Prop Type: 螺旋桨型号:

3blade prop / 9.3inch diam (50739)

2blade prop / 11.4inch diam (50742,50743)

Prop Speed at Full Power: 转速:

Max. 1250 rpm underwater (50739)

Max. 1500 rpm underwater (50742,50743)

Battery Type Required: 电池要求:

1 x105AH Deep Cycle (50739)

2 x105AH Deep Cycle (50742)

3 x105AH Deep Cycle (50743)

Steering: 转向操控:

360 degree control (All)

Decibel Level (db): 噪音等级:

50db (All)

Weight (N.W.): 重量:

13.5kg / 14.7kg / 16.4kg

Shaft Type: 主杆类型:

Cast Aluminium (All)

Shaft Length: 主杆长度:

1370mm / 1490mm / 1490mm

Colour: 颜色:

Black (All)

Max Boat Length (Suggestion): 船长:

5.5m / 6.5m / 7m

RETRACTABLE
推进器收放踏板

Press it to deploy or stow the motor easily.

50802N REMOTE CONTROLLER
无线遥控器

Function: On/Off, Speed Up/Down, Full Speed, Turn Left/Right, Pairing.

Not Included! FOOT REMOTE CONTROLLER
脚踏控制器 (选配)

LCD Display; Function: On/Off, Speed Up/Down, Full Speed, Turn Left/Right, Pairing.

MOTOR FIN
独立鳍翼设计

Separated design for propeller protection.

POWER DISPLAY
电源显示

Display 5 levels of battery power.

The Cayman B Bow Mount Trolling Motor aimed at serious fishermen who require the versatility of guiding their motor via a wireless hand remote or wireless foot remote pedal. This feature packed bow mount trolling motor comes standard with a wireless hand control, sacrificial anode and encapsulated electronics. Supplied standard with all the necessary stainless steel nuts and bolts to fit straight onto the boat, or option up with our quick release plate with a foot print of just 120mm x 200mm when not in use. All motors feature LED battery meters. Upgraded packages are available which include the wireless foot remote controller and quick release mounting plate. Suitable for both salt and fresh water.

MODEL: CAYMAN B/with GPS

50736
12V-55Lbs

50737
24V-80Lbs

50738
36V-101Lbs

遥控GPS系列 / Remote Control GPS Series

Wireless Remote Controller
(50806) Included!



The New
HELMSMAN system
Available Now!

(Both ios & Andriod)

单向无级调速
One-Way Stepless Speed

3 Quick Retract Bracket



Wireless Foot
Remote Controller
For Option!

(50805)
Not Included!

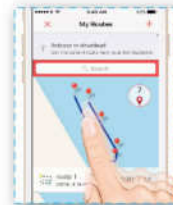

Depth Collar 2

Durable Motor 6

DD Brush Motor
有刷直驱电机

5 Anti-impact propeller

图片与实物略有不同!
Actual model may vary from image!



4 Advanced Functions

- Record Route
- Navigation
- Cruise Control
- Anchor



SPECIFICATIONS

MODEL: 产品型号:
50736 / 50737 / 50738

Power of thrust: 峰值推力:
55Lbs / 80Lbs / 101Lbs

Max Voltage: 电压:
DC 12V / 24V / 36V

Power - Max: 功率:
600W / 1080W / 1620W

Amp - Max: 电流:
50A / 45A / 45A

Depth Adjustment: 深度调节:
Depth collar (All)

Prop Type: 螺旋桨型号:
3blade prop / 9.3inch diam (50736)
2blade prop / 11.4inch diam (50737,50738)

Prop Speed at Full Power: 转速:
Max. 1250 rpm underwater (50736)
Max. 1500 rpm underwater (50737,50738)

Battery Type Required: 电池要求:
1 x105AH Deep Cycle (50736)
2 x105AH Deep Cycle (50737)
3 x105AH Deep Cycle (50738)

Steering: 转向操控:
360 degree control (All)

Decibel Level (db): 噪音等级:
50db (All)

Weight (N.W.): 重量:
13.9kg / 15.1kg / 16.8kg

Shaft Type: 主杆类型:
Cast Aluminium (All)

Shaft Length: 主杆长度:
1370mm / 1490mm / 1490mm

Colour: 颜色:
Black (All)

Max Boat Length (Suggestion): 船长:
5.5m / 6.5m / 7m



GPS SMART NAVIGATION SYSTEM
GPS智能导航系统

1. Record Routes
2. GPS Navigation
3. Anchor
4. Cruise Control



SMART PHONE OPERATING SYSTEM
智能手机终端控制

Download the
Helmsman APP to
operate all functions
with your smart
phone.



POWER DISPLAY
电源显示

Display 5 levels of
battery power.



RETRACTABLE
推进器收放踏板

Press it to deploy
or stow the motor
easily.



REMOTE CONTROLLER
无线遥控器

Function: On/Off,
Speed Up/Down,
Full Speed, Turn
Left/Right, Pairing.

The Cayman B/with GPS Bow Mount Trolling Motor aimed at serious fishermen who require the versatility of guiding their motor via a wireless hand remote or wireless foot remote pedal. This feature packed bow mount trolling motor comes standard with a wireless hand control, sacrificial anode and encapsulated electronics. Supplied standard with all the necessary stainless steel nuts and bolts to fit straight onto the boat, or option up with our quick release plate with a foot print of just 120mmx200mm when not in use. GPS smart navigation system and smart phone operation system are available for all motors. All motors feature LED battery meters. Upgraded packages are available which include the wireless foot remote controller and quick release mounting plate. Suitable for both salt and fresh water.

MODEL: **HTT**

51200 / 3.5HP-2 Stroke
Outboard Motor

3.5匹二冲程汽油舷外机



图片与实物略有不同!
Actual model may vary from image!



SPECIFICATIONS

MODEL: 产品型号:
51200

Power of thrust: 峰值推力:
3.5HP

Type of Engine: 引擎类型:
2 Stroke

Prop Type: 螺旋桨型号:
3 blade prop / 7.5inch diam

Prop Speed at Full Power: 转速:
Max.2400 rpm underwater

Steering: 转向操控:
360 degree control

Decibel Level (db): 噪音等级:
65db

Weight (N.W.): 重量:
15.6kg

Capacity of Oil Box: 油箱容量:
2700ml

Cooling System: 冷却系统:
Water Cooling

Shaft Type: 主杆类型:
Cast Aluminium

Max Boat Length (Suggestion): 船长:
6m



SPEED CONTROL
油门变速调节

Provide stepless forward and reverse speed control.



THROTTLE ADJUSTER
油门定位

This knob provide stepless throttle control.



FORWARD & REVERSE
正反推进调节

This handle has three modes of operating:
Forward / Off / Reverse



EMERGENCY STOP
紧急熄火开关

Kill switch available if the emergency happened.



WATER COOLING
循环式水冷系统

Water cooling system is available when the motor is working.

The HTT-3.5 is excellent for the propulsion of a wide range of boats and waterways. This powerful motor is equipped with adjustable speed control and a safety lanyard. The motor can easily be tilted in and out of the water by way of a quick lock, so you can motor in virtually any water. As an added safety feature, the HTT-3.5 is equipped with an auto propeller cut-out in the event of a collision. The HTT-3.5 model suitable for both salt and fresh water.

MODEL:

50728 / With Gear Box
PROTRUAR G 3.0/24V

50713 / With Gear Box
PROTRUAR G 4.0/24V

电动无刷推进器系列



Kill Switch Included

图片与实物略有不同!
Actual model may vary from image!



SPECIFICATIONS

MODEL: 产品型号:
50728 / 50713

Shaft Power: 动力:
3HP / 4HP

Comparable petrol outboards (thrust):
等效汽油机:
4HP / 5HP

Peak Thrust in Lbs: 峰值推力:
110Lbs / 130Lbs

Max Voltage: 电压:
DC 24V (All)

Power - Max: 功率:
1200W / 1800W

Amp - Max: 电流:
50A / 75A

Depth Adjustment: 深度调节:
Depth collar (All)

Prop Type: 螺旋桨型号:
3blade prop / 11.8inch diam (All)

Prop Speed at Full Power: 转速:
Max. 630 rpm underwater (50728)
Max. 1100 rpm underwater (50713)

Battery Type Required: 电池要求:
2x105AH Deep Cycle (50728)
2x120AH Deep Cycle (50713)

Steering: 转向操控:
360 degree control (All)

Decibel Level (db): 噪音等级:
65db (All)

Weight (N.W.): 重量:
8.0kg / 8.3kg

Shaft Type: 主杆类型:
Cast Aluminium / Stainless Steel

Shaft Length: 主杆长度:
900mm / 1000mm

Colour: 颜色:
Black (All)

Max Boat Length (Suggestion): 船长:
7m / 7.5m



FOLDING HANDLE
操控杆角度调节

This Trolling handle has the folding functions. Folding angle:100°



TILTING THE MOTOR
角度调节支架

Offer 7 levels of tilting position.



SPEED CONTROL
无级变速调节+熄火钥匙

Digital technology provide stepless forward and reverse speed control.



POWER DISPLAY
电源显示

Display 5 levels of battery power.



PROP-CLUTCH
螺旋桨离合功能

Break away running prop when it is block. This prevent prop damage.

The Protruar G is equipped with a brushless 3.0/4.0 24volt motor and is excellent for the propulsion of a wide range of boats and waterways. This powerful motor is equipped with step-less adjustable speed control and a safety lanyard. The motor can easily be tilted in and out of the water and the trim height is adjustable by way of a quick lock, so you can motor in virtually any water. As an added safety feature, the Protruar G is equipped with an auto propeller cut-out in the event of a collision. The Protruar G models also features an LED battery level indicator. Suitable for both salt and fresh water.

MODEL:

50762 / With LIPO Battery
ULTIMA 55Lbs/29.6V

电动无刷推进器带可充电锂电池豪华系列

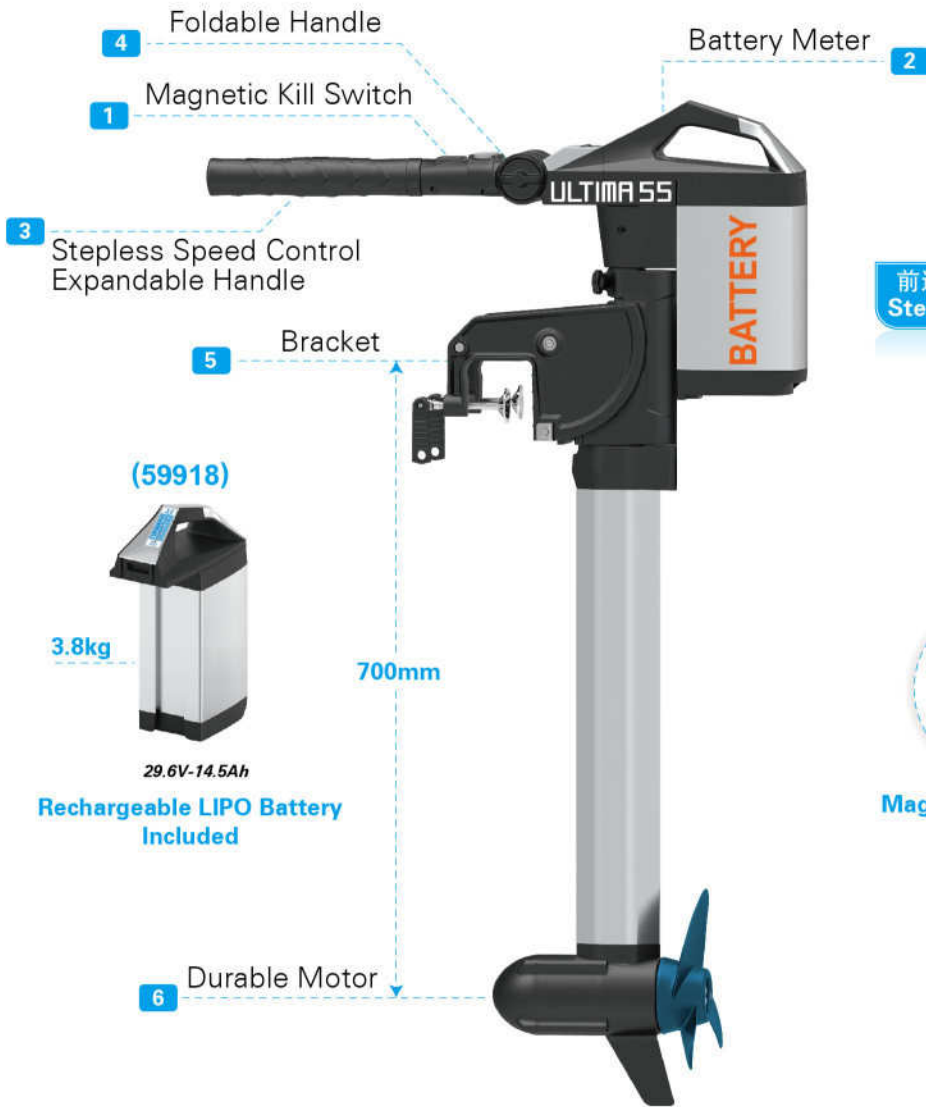

前进/后退无级调速
Stepless Speed F/R

(59918)



3.8kg

700mm

29.6V-14.5Ah

Rechargeable LIPO Battery
Included



Magnetic Kill Switch
Included

SPECIFICATIONS

MODEL: 产品型号:
50762

Shaft Power: 动力:
55Lbs

Comparable petrol outboards (thrust):
等效汽油机:
1.5HP

Peak Thrust in Lbs: 峰值推力:
55Lbs

Max Voltage: 电压:
DC 29.6V

Power - Max: 功率:
380W

Amp - Max: 电流:
13A

Depth Adjustment: 深度调节:
Not Available

Prop Type: 螺旋桨型号:
3blade prop / 9.3inch diam

Prop Speed at Full Power: 转速:
Max. 1200 rpm underwater

Battery Type Required: 电池要求:
29.6V, 14.5Ah rechargeable LIPO battery

Charging Time: 充电时间:
4-5 hours

Steering: 转向操控:
360 degree control

Decibel Level (db): 噪音等级:
≤55db

Weight (N.W.): 重量:
13.2kg

Shaft Type: 主杆类型:
Cast Aluminium

Shaft Length: 主杆长度:
700mm

Colour: 颜色:
Black

Max Boat Length (Suggestion): 船长:
5.5m



SPEED CONTROL
推进变速调节

Digital technology provide stepless forward and reverse speed control. With magnetic kill switch.

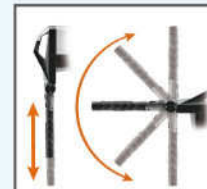

EXPAND & FOLD
伸缩+角度调节操纵手柄

400mm length of handle extension. Trolling handle has folding functions. Folding angle:180°



TILTING THE MOTOR
角度调节支架

Offer 7 levels of tilting position.



RECHARGEABLE BATTERY
可充电锂电池

Separated rechargeable LIPO battery included.



POWER DISPLAY
电源显示

Display 5 levels of battery power.

Output: 4A Charger Included

Input: 100V-240V



充电器已配备

MODEL	Max.speed (km/h)	Range (km)	Running time hh:mm
50762			
Slow	2.7	28	10:30
Half throttle	4.5	15	03:30
Full throttle	7.4	8.6	01:10

图片与实物略有不同!
Actual model may vary from image!



The Ultima 55Lbs is equipped with a brushless 55Lbs/29.6volt motor and is excellent for the propulsion of a wide range of boats and waterways. This powerful motor is equipped with step-less adjustable speed control and a safety lanyard. The motor can easily be tilted in and out of the water. So you can motor in virtually any water. All the motor is included the high-performance lithium battery (29.6V). The Ultima 55Lbs model also features an LED battery level indicator. Suitable for both salt and fresh water.

MODEL:

50741 / With LIPO Battery
ULTIMA 3.0/29.6V

电动无刷推进器带可充电锂电池豪华系列



前进/后退无级调速
Stepless Speed F/R



Magnetic Kill Switch Included

DD Brushless Motor
无刷直驱电机

Output: 4A Charger Included

Input: 100V-240V



充电器已配备

MODEL	Max.speed (km/h)	Range (km)	Running time hh:mm
50741			
Slow	3.4	34	10:05
Half throttle	5.1	15.3	03:10
Full throttle	8.8	5.8	00:40



图片与实物略有不同!
Actual model may vary from image!

SPECIFICATIONS

MODEL: 产品型号:
50741

Shaft Power: 动力:
3HP

Comparable petrol outboards (thrust):
等效汽油机:

4HP
Peak Thrust in Lbs: 峰值推力:
110Lbs

Max Voltage: 电压:
DC 29.6V

Power - Max: 功率:
1030W

Amp - Max: 电流:
35A

Depth Adjustment: 深度调节:
Not Available

Prop Type: 螺旋桨型号:
3blade prop / 9.3inch diam

Prop Speed at Full Power: 转速:
Max. 1530 rpm underwater

Battery Type Required: 电池要求:
29.6V, 20.3AH rechargeable LIPO battery

Charging Time: 充电时间:
6-7 hours

Steering: 转向操控:
360 degree control

Decibel Level (db): 噪音等级:
≤55db

Weight (N.W.): 重量:
15.9kg

Shaft Type: 主杆类型:
Cast Aluminium

Shaft Length: 主杆长度:
700mm

Colour: 颜色:
Black

Max Boat Length (Suggestion): 船长:
7m



SPEED CONTROL
推进变速调节

Digital technology provide stepless forward and reverse speed control. With magnetic kill switch.



EXPAND & FOLD
伸缩+角度调节操纵手柄

400mm length of handle extension. Trolling handle has folding functions. Folding angle:180°



TILTING THE MOTOR
角度调节支架

Offer 7 levels of tilting position.



RECHARGEABLE BATTERY
可充电锂电池

Separated rechargeable LIPO battery included.



POWER DISPLAY
电源显示

Display 5 levels of battery power.

The Ultima 3.0 is equipped with a brushless 3.0/29.6volt motor and is excellent for the propulsion of a wide range of boats and waterways. This powerful motor is equipped with step-less adjustable speed control and a safety lanyard. The motor can easily be tilted in and out of the water. So you can motor in virtually any water. All the motor is included the high-performance lithium battery (29.6V). The Ultima 3.0 model also features an LED battery level indicator. Suitable for both salt and fresh water.

MODEL:

50744
PROTRUAR 1.0/12V

50745
PROTRUAR 2.0/24V

50715
PROTRUAR 3.0/24V

电动无刷推进器系列



图片与实物略有不同!
Actual model may vary from image!



SPECIFICATIONS

MODEL: 产品型号:
50744 / 50745 / 50715

Shaft Power: 动力:
1HP / 2HP / 3HP

Comparable petrol outboards (thrust):
等效汽油机:

2HP / 3HP / 4HP

Peak Thrust in Lbs: 峰值推力:
65Lbs / 85Lbs / 110Lbs

Max Voltage: 电压:
DC 12V / 24V / 24V

Power - Max: 功率:
600W / 960W / 1440W

Amp - Max: 电流:
50A / 40A / 60A

Depth Adjustment: 深度调节:
Depth collar (All)

Prop Type: 螺旋桨型号:
3blade prop / 9.3inch diam (All)

Prop Speed at Full Power: 转速:
Max. 1250 rpm underwater (50744)

Max. 1350 rpm underwater (50745)

Max. 1450 rpm underwater (50715)

Battery Type Required: 电池要求:
1x105AH Deep Cycle (50744)

2x105AH Deep Cycle (50745,50715)

Steering: 转向操控:
360 degree control (All)

Decibel Level (db): 噪音等级:
<55db (All)

Weight (N.W.): 重量:
6.6kg / 6.9kg / 9.9kg

Shaft Type: 主杆类型:
Cast Aluminium (50744,50745)

Stainless Steel (50715)

Shaft Length: 主杆长度:
900mm (All)

Colour: 颜色:
Black (All)

Max Boat Length (Suggestion): 船长:
6m / 6.5m / 7m



TILTING THE MOTOR
角度调节支架

Offer 10 or 7 levels
of tilting position.



SPEED CONTROL
推进变速调节

Digital technology
provide stepless
forward and reverse
speed control.



EXPAND & FOLD
伸缩+角度调节操纵手柄

400mm length of
handle extension.
Trolling handle has
folding functions.
Folding angle:180°



POWER DISPLAY
电源显示

Display 3 levels of
battery power.

The Protruar is equipped with a brushless 1.0/2.0/3.0 12V or 24V motor and is excellent for the propulsion of a wide range of boats and waterways. This powerful motor is equipped with step-less adjustable speed control and a safety lanyard. The motor can easily be tilted in and out of the water and the trim height is adjustable by way of a quick lock, so you can motor in virtually any water. The Protruar models also features an LED battery level indicator. Suitable for both salt and fresh water.

MODEL:

50719
PROTRUAR 5.0/24V

电动无刷推进器系列



图片与实物略有不同!
Actual model may vary from image!



SPECIFICATIONS

MODEL: 产品型号:
50719

Shaft Power: 动力:
5HP

Comparable petrol outboards (thrust):
等效汽油机:
6HP

Peak Thrust in Lbs: 峰值推力:
160Lbs

Max Voltage: 电压:
DC 24V

Power - Max: 功率:
2520W

Amp - Max: 电流:
105A

Depth Adjustment: 深度调节:
Depth collar

Prop Type: 螺旋桨型号:
3blade prop / 10.7inch diam

Prop Speed at Full Power: 转速:
Max. 1450 rpm underwater

Battery Type Required: 电池要求:
2x120AH Deep Cycle

Steering: 转向操控:
360 degree control

Decibel Level (db): 噪音等级:
≤55db

Weight (N.W.): 重量:
14kg

Shaft Type: 主杆类型:
Stainless Steel

Shaft Length: 主杆长度:
1000mm

Colour: 颜色:
Black

Max Boat Length (Suggestion): 船长:
8m



The Protruar is equipped with a brushless 5.0/24V motor and is excellent for the propulsion of a wide range of boats and waterways. This powerful motor is equipped with step-less adjustable speed control and a safety lanyard. The motor can easily be tilted in and out of the water and the trim height is adjustable by way of a quick lock, so you can motor in virtually any water. The Protruar model also features an LED battery level indicator. Suitable for both salt and fresh water.

MODEL:

50749
VENTURA T 5.0/24V

电动无刷推进器豪华系列



SPECIFICATIONS

MODEL: 产品型号:

50749

Shaft Power: 动力:

5HP

Comparable petrol outboards (thrust):
等效汽油机:

6HP

Peak Thrust in Lbs: 峰值推力:

160Lbs

Max Voltage: 电压:

DC 24V

Power - Max: 功率:

2520W

Amp - Max: 电流:

105A

Depth Adjustment: 深度调节:

Not Available

Prop Type: 螺旋桨型号:

3blade prop / 10.7inch diam

Prop Speed at Full Power: 转速:

Max. 1450 rpm underwater

Battery Type Required: 电池要求:

2x120AH Deep Cycle

Steering: 转向操控:

360 degree control

Decibel Level (db): 噪音等级:

≤55db

Weight (N.W.): 重量:

15.7kg

Shaft Type: 主杆类型:

Stainless Steel + Aluminium

Shaft Length: 主杆长度:

700mm

Colour: 颜色:

Black

Max Boat Length (Suggestion): 船长:

8m



The Ventura T is equipped with a brushless 5.0/24V motor and is excellent for the propulsion of a wide range of boats and waterways. This powerful motor is equipped with step-less adjustable speed control and a safety lanyard. The motor can easily be tilted in and out of the water, so you can motor in virtually any water. The Ventura T model also features an LED battery level indicator. Suitable for both salt and fresh water.



MODEL:

50731
ARMADA T 8.0/48V

50732
ARMADA T 10.0/48V

电动无刷推进器豪华系列

Brushless Motor
With Gear Box

无刷齿轮箱变速电机

Stepless Speed Control
Expandable Handle

1

Battery Meter

2

Foldable Handle

3

Bracket

4

前进/后退无级调速
Stepless Speed F/R

670mm

Gear Box

5

变速齿轮箱



Magnetic Kill Switch
Included

图片与实物略有不同！
Actual model may vary from image!



SPECIFICATIONS

MODEL: 产品型号:

50731 / 50732

Shaft Power: 动力:
8HP / 10HP

Comparable petrol outboards (thrust):
等效汽油机:
10HP / 12HP

Peak Thrust in Lbs: 峰值推力:
250Lbs / 300Lbs

Max Voltage: 电压:
DC 48V (All)

Power - Max: 功率:
4320W / 6000W

Amp - Max: 电流:
90A / 125A

Depth Adjustment: 深度调节:
Not Available (All)

Prop Type: 螺旋桨型号:
3blade prop / 11.8inch diam (All)

Prop Speed at Full Power: 转速:
Max. 1050 rpm underwater (50731)
Max. 1200 rpm underwater (50732)

Battery Type Required: 电池要求:
4x120AH Deep Cycle (All)

Steering: 转向操控:
360 degree control (All)

Decibel Level (db): 噪音等级:
75db (All)

Weight (N.W.): 重量:
27.3kg / 28.8kg

Shaft Type: 主杆类型:
Cast Aluminium (All)

Shaft Length: 主杆长度:
670mm (All)

Colour: 颜色:
Black (All)

Max Boat Length (Suggestion): 船长:
9m (All)



SPEED CONTROL
推进变速调节

Digital technology provide stepless forward and reverse speed control. With magnetic kill switch.



EXPAND & FOLD
伸缩+角度调节操纵手柄

360mm length of handle extension. Trolling handle has folding functions. Folding angle:180°



TILTING THE MOTOR
角度调节支架

Offer 3 levels of tilting position, the angle is 18、27、60 degree.



LED POWER DISPLAY
LED电源电压显示

Can show you the battery power in anytime.



WATER COOLING
循环式水冷系统

Water cooling system is available when the motor is working forward.

The Armada T is equipped with a brushless 8.0/10.0 48V motor and is excellent for the propulsion of a wide range of boats and waterways. This powerful motor is equipped with step-less adjustable speed control and a safety lanyard. The motor can easily be tilted in and out of the water, so you can motor in virtually any water. The Armada T models also features an LED battery level indicator. Suitable for both salt and fresh water.

MODEL:

50756
PROTRUAR 3.0/12V

电动无刷推进器低电压大功率系列



图片与实物略有不同!
Actual model may vary from image!

SPECIFICATIONS

MODEL: 产品型号:
50756

Shaft Power: 动力:
3HP

Comparable petrol outboards (thrust):
等效汽油机:
4HP

Peak Thrust in Lbs: 峰值推力:
110Lbs

Max Voltage: 电压:
DC 12V

Power - Max: 功率:
900W

Amp - Max: 电流:
75A

Depth Adjustment: 深度调节:
Depth collar

Prop Type: 螺旋桨型号:
3blade prop / 10.7inch diam

Prop Speed at Full Power: 转速:
Max. 1250 rpm underwater

Battery Type Required: 电池要求:
1x120AH Deep Cycle

Steering: 转向操控:
360 degree control

Decibel Level (db): 噪音等级:
55db

Weight (N.W.): 重量:
14.5kg

Shaft Type: 主杆类型:
Stainless Steel

Shaft Length: 主杆长度:
1000mm

Colour: 颜色:
Black

Max Boat Length (Suggestion): 船长:
7m



The Protruar is equipped with a brushless 3.0/12V motor and is excellent for the propulsion of a wide range of boats and waterways. This powerful motor is equipped with step-less adjustable speed control and a safety lanyard. The motor can easily be tilted in and out of the water and the trim height is adjustable by way of a quick lock, so you can motor in virtually any water. The Protruar model also features an LED battery level indicator. Suitable for both salt and fresh water.

MODEL: Steering Wheel Series

50752
VENTURA F 5.0/24V

电动无刷推进器豪华方向盘系列



Steering Wheel Unit
Is Required!



Magnetic Kill Switch
Included



DD Brushless Motor
无刷直驱电机

图片与实物略有不同!
Actual model may vary from image!



SPECIFICATIONS

MODEL: 产品型号:

50752

Shaft Power: 动力:
5HP

Comparable petrol outboards (thrust):
等效汽油机:
6HP

Peak Thrust in Lbs: 峰值推力:
160Lbs

Max Voltage: 电压:
DC 24V

Power - Max: 功率:
2520W

Amp - Max: 电流:
105A

Depth Adjustment: 深度调节:
Not Available

Prop Type: 螺旋桨型号:
3blade prop / 10.7inch diam

Prop Speed at Full Power: 转速:
Max. 1450 rpm underwater

Battery Type Required: 电池要求:
2x120AH Deep Cycle

Steering: 转向操控:
360 degree control

Decibel Level (db): 噪音等级:
≤55db

Weight (N.W.): 重量:
15.7kg

Shaft Type: 主杆类型:
Stainless Steel + Aluminium

Shaft Length: 主杆长度:
800mm

Colour: 颜色:
Black

Max Boat Length (Suggestion): 船长:
8m

Included!



STEPLESS SPEED CONTROLLER
无级变速器及感应开关

Digital technology provide stepless forward and reverse speed control. With magnetic kill switch



TILTING THE MOTOR
角度调节支架

Offer 4 levels of tilting position with 3 angles additional option.



STEERING WHEEL CONTROL
另购方向盘操控

An additional steering wheel unit is required. The steering angle: from -45° to +45°.



LED POWER DISPLAY
LED电源电压显示

Can show you the battery power in anytime.

The Ventura F is equipped with a brushless 5.0/24V motor and is excellent for the propulsion of a wide range of boats and waterways. This powerful motor is equipped with step-less adjustable speed control and a safety lanyard. The motor can easily be tilted in and out of the water, so you can motor in virtually any water. The Ventura F model also features an LED battery level indicator. An additional steering wheel unit is required. Suitable for both salt and fresh water.

MODEL: *Steering Wheel Series*

50733
ARMADA F 8.0/48V

50734
ARMADA F 10.0/48V

电动无刷推进器豪华方向盘系列

Brushless Motor
With Gear Box

无刷齿轮箱变速电机



59920

Steering Wheel Unit
Is Required!



Magnetic Kill Switch
Included



Battery Meter

1

Bracket

2

670mm



前进/后退无级调速
Stepless Speed F/R

Gear Box

3

变速齿轮箱

图片与实物略有不同!
Actual model may vary from image!



SPECIFICATIONS

MODEL: 产品型号:
50733 / 50734

Shaft Power: 动力:
8HP / 10HP

Comparable petrol outboards (thrust):
等效汽油机:
10HP / 12HP

Peak Thrust in Lbs: 峰值推力:
250Lbs / 300Lbs

Max Voltage: 电压:
DC 48V (All)

Power - Max: 功率:
4320W / 6000W

Amp - Max: 电流:
90A / 125A

Depth Adjustment: 深度调节:
Not Available (All)

Prop Type: 螺旋桨型号:
3blade prop / 11.8inch diam (All)

Prop Speed at Full Power: 转速:
Max. 1050 rpm underwater (50733)
Max. 1200 rpm underwater (50734)

Battery Type Required: 电池要求:
4x120AH Deep Cycle (All)

Steering: 转向操控:
360 degree control (All)

Decibel Level (db): 噪音等级:
75db (All)

Weight (N.W.): 重量:
27.3kg / 28.8kg

Shaft Type: 主杆类型:
Cast Aluminium (All)

Shaft Length: 主杆长度:
670mm (All)

Colour: 颜色:
Black (All)

Max Boat Length (Suggestion): 船长:
9m (All)

Included!



STEPLESS SPEED CONTROLLER
无级变速器及感应开关

Digital technology
provide stepless
forward and reverse
speed control. With
magnetic kill switch



TILTING THE MOTOR
角度调节支架

Offer 4 levels of
tilting position with
3 angles additional
option.



Not Included!
STEERING WHEEL CONTROL
另购方向盘操控

An additional
steering wheel unit
is required.
The steering angle:
from -45° to +45°.



LED POWER DISPLAY
LED电源电压显示

Can show you the
battery power in
anytime.



WATER COOLING
循环式水冷系统

Water cooling
system is available
when the motor is
working forward.

The Armada F is equipped with a brushless 8.0/10.0 48V motor and is excellent for the propulsion of a wide range of boats and waterways. This powerful motor is equipped with step-less adjustable speed control and a safety lanyard. The motor can easily be tilted in and out of the water, so you can motor in virtually any water. The Armada F models also features an LED battery level indicator. An additional steering wheel unit is required. Suitable for both salt and fresh water.

MODEL: HASWING FISHING KAYAK

54601 With 40Lbs Electric Trolling Motor
Winix

SINGLE



40Lbs Electric Trolling Motor Included!



12V Water Pump For Option!

8

水泵排水!

Not Included

图片与实物略有不同!
Actual model may vary from image!



KAYAK SPECIFICATIONS

MODEL: 产品型号:

54601

NAME: 名称:

Single Winix Kayak

Dimension: 尺寸:

L3.3m × W0.8m × H0.4m

Weight: 重量:

60kg

Max Load: 载重:

150kg

Steering: 转向操控:

Rudder control by Foot

MOTOR SPECIFICATIONS

Power of thrust: 峰值推力:

40Lbs

Max Voltage: 电压:

DC 12V

Power - Max: 功率:

500W

Amp - Max: 电流:

42A

Depth Adjustment: 深度调节:

Not available

Prop Type: 螺旋桨型号:

2 blade prop 9inch diam

Prop Speed at Full Power: 转速:

Max. 1380 rpm underwater

Battery Type Required: 电池要求:

1x105AH deep cycle

Decibel Level (db): 噪音等级:

≤50db

Driving Type: 驱动模式:

5 Forward / 3 Reverse control



STAND UP SUPPORT
配备站立扶手

For more safety and wide-view.



ROD HOLDERS
配备鱼竿支架

The necessary fishing assistants Included.



RUDDER CONTROL
脚控尾舵方向

Rudder control by foot.



RETRACTABLE STABILIZER
浮筒展收功能

This stability to allow you stand up and move about with confidence when stationary.



12V WATER PUMP
12V 排水泵(另购)

Can drain away the water easily.

Not Included

The new innovative Haswing Fishing Kayak series, utilising the 40Lbs electric trolling motor; this kayak has a fully integrated steering and electric propulsion system. The kayak is equipped with retractable side pods for stability, this allows you to stand up and move about with confidence when stationary. The integrated 40Lbs electric outboard provides a generous amount of propulsion, and the tilt trim system allows for smooth beach landings. The Kayak is equipped with Rod holders, storage centre, Stain- less Steel stand up rail, carry handles, cleats, elevated plastic seat and much more!

MODEL: HASWING FISHING KAYAK

54602 With
40Lbs Electric
Trolling Motor

TWIN



40Lbs Electric Trolling Motor Included!

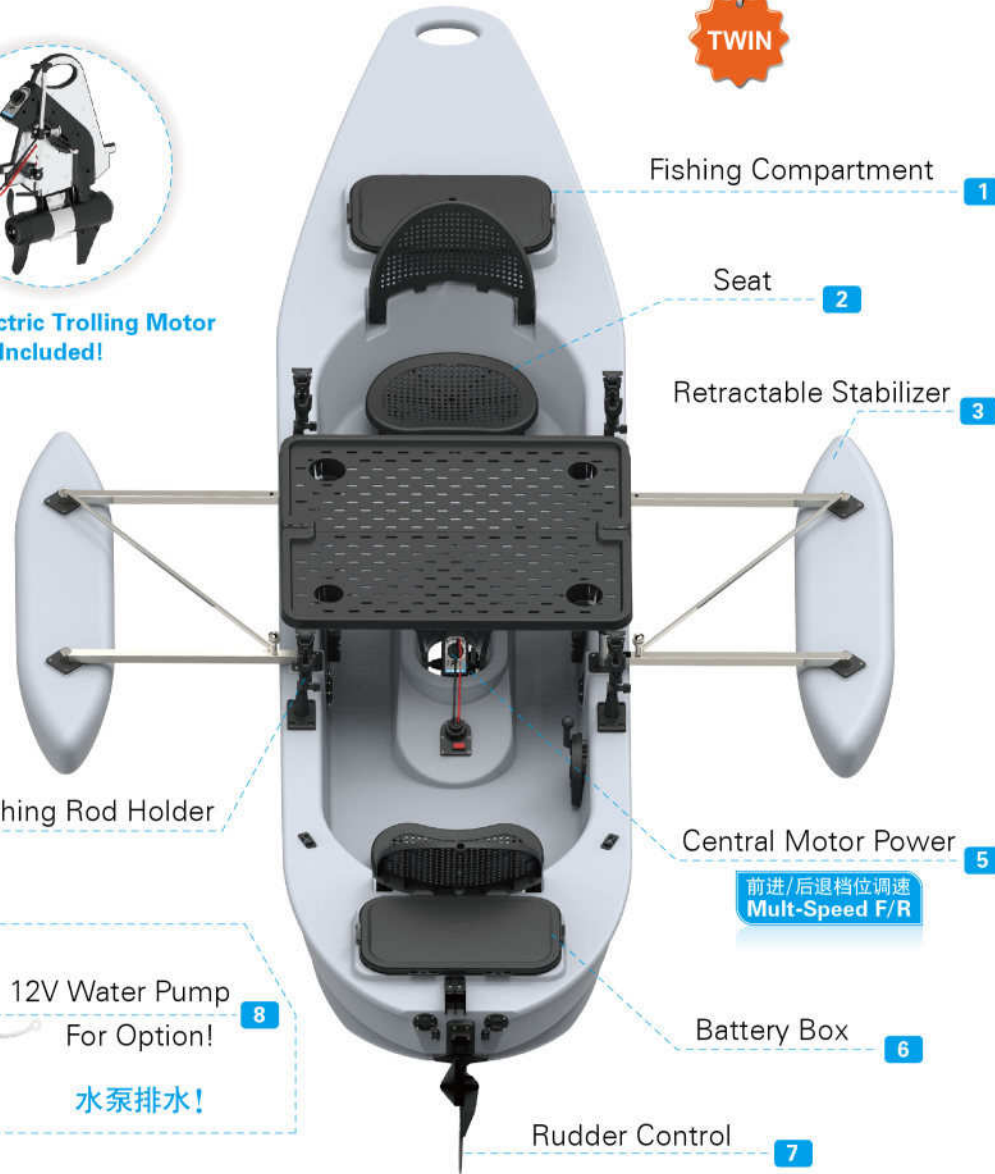

Fishing Compartment 1

Seat 2

Retractable Stabilizer 3

Fishing Rod Holder 4

Central Motor Power 5

前进/后退档位调速
Multi-Speed F/R

Battery Box 6

Rudder Control 7



12V Water Pump For Option!

Not Included

水泵排水!

图片与实物略有不同!
Actual model may vary from image!



KAYAK SPECIFICATIONS

MODEL: 产品型号:

54602

NAME: 名称:

Twin Windex Kayak

Dimension: 尺寸:

L3.8m × W0.8m × H0.4m

Weight: 重量:

67kg

Max Load: 载重:

350kg

Steering: 转向操控:

Rudder control by Foot

MOTOR SPECIFICATIONS

Power of thrust: 峰值推力:

40Lbs

Max Voltage: 电压:

DC 12V

Power - Max: 功率:

500W

Amp - Max: 电流:

42A

Depth Adjustment: 深度调节:

Not available

Prop Type: 螺旋桨型号:

2 blade prop 9inch diam

Prop Speed at Full Power: 转速:

Max. 1380 rpm underwater

Battery Type Required: 电池要求:

1x105AH deep cycle

Decibel Level (db): 噪音等级:

≤50db

Driving Type: 驱动模式:

5 Forward / 3 Reverse control



TWO TAIL WHEELS
船尾拖轮设计

Two tail wheels included, Easy to move the boat by single person.



SEAT AND TABLE
双座椅和置物台

Include front and rear seats. With table in the middle.



RUDDER CONTROL
脚控尾舵方向

Rudder control by foot.



RETRACTABLE STABILIZER
浮筒展收功能

This stability to allow you stand up and move about with confidence when stationary.



12V WATER PUMP
12V 排水泵(另购)

Can drain away the water easily.

Not Included

The new innovative Haswing Fishing Kayak series, utilising the 40Lbs electric trolling motor; this kayak has a fully integrated steering and electric propulsion system. Two retractable side stabilizer allow you stand up and move about with confidence when stationary. The integrated 40Lbs electric outboard provides a generous amount of propulsion, and the tilt trim system allows for smooth beach landings. The Kayak is equipped with Rod holders, storage centre, carry handles, table, elevated plastic seats and much more! Two peoples can enjoy.

MODEL: HASWING FISHING KAYAK

54603 With 40Lbs Electric Trolling Motor
Winfix

SINGLE



40Lbs Electric Trolling Motor Included!

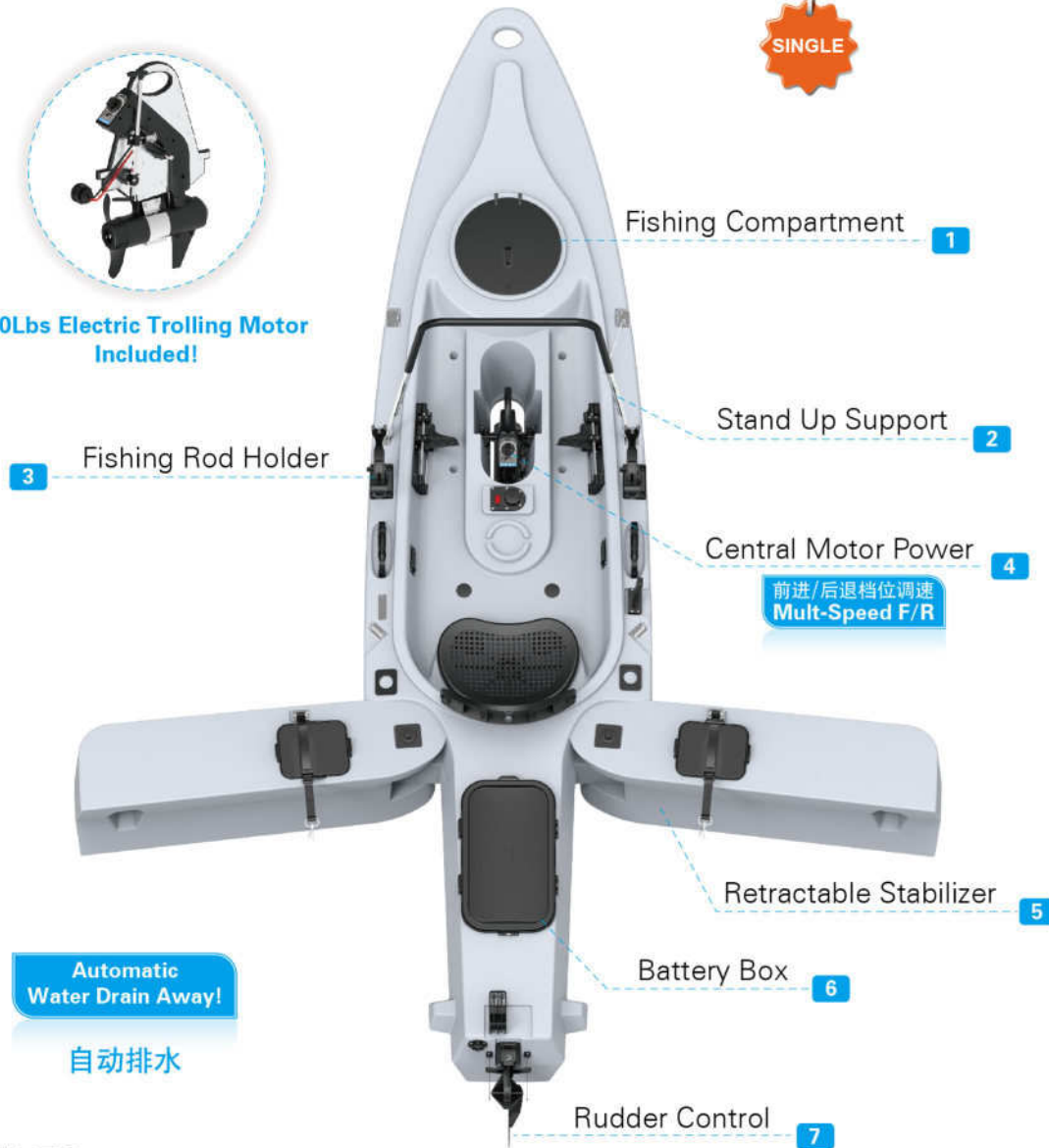

Automatic Water Drain Away!

自动排水

图片与实物略有不同!
Actual model may vary from image!



KAYAK SPECIFICATIONS

MODEL: 产品型号:
54603

NAME: 名称:
Single Winfix Kayak

Dimension: 尺寸:
L3.3m × W0.8m × H0.4m

Weight: 重量:
60kg

Max Load: 载重:
150kg

Steering: 转向操控:
Rudder control by Foot

MOTOR SPECIFICATIONS

Power of thrust: 峰值推力:
40Lbs

Max Voltage: 电压:
DC 12V

Power - Max: 功率:
500W

Amp - Max: 电流:
42A

Depth Adjustment: 深度调节:
Not available

Prop Type: 螺旋桨型号:
2 blade prop 9inch diam

Prop Speed at Full Power: 转速:
Max. 1380 rpm underwater

Battery Type Required: 电池要求:
1x105AH deep cycle

Decibel Level (db): 噪音等级:
≤50db

Driving Type: 驱动模式:
5 Forward / 3 Reverse control



STAND UP SUPPORT
配备站立扶手

For more safety and wide-view.



ROD HOLDERS
配备鱼竿支架

The necessary fishing assistants Included.



RUDDER CONTROL
脚控尾舵方向

Rudder control by foot.



RETRACTABLE STABILIZER
浮筒展收功能

This stability to allow you stand up and move about with confidence when stationary.



WATER DRAIN OFF
自动排水功能

4 drain holes was designed. Can drain away the water automatically.

The new innovative Haswing Fishing Kayak series, utilising the 40Lbs electric trolling motor; this kayak has a fully integrated steering and electric propulsion system. The kayak is equipped with retractable side pods for stability, this allows you to stand up and move about with confidence when stationary. The integrated 40Lbs electric outboard provides a generous amount of propulsion, and the tilt trim system allows for smooth beach landings. The Kayak is equipped with Rod holders, storage centre, Stain- less Steel stand up rail, carry handles, cleats, elevated plastic seat and much more!

MODEL: HASWING FISHING BOAT

54604
Winpab

Portable
Assembly Boat

Portable Assembly Boat

SINGLE
or
TWIN

便携式拼装船

1 Fishing Compartment

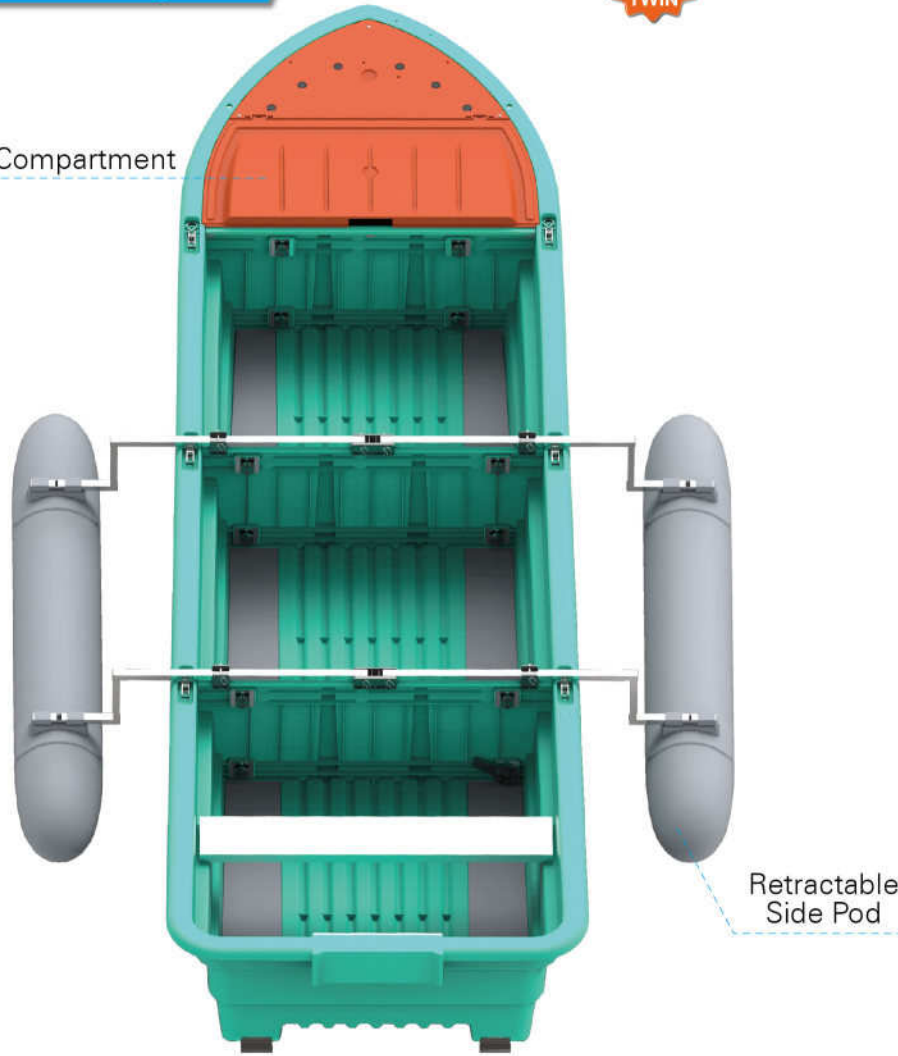

Retractable
Side Pod

图片与实物略有不同!
Actual model may vary from image!



Be easily Assembled by 4 Parts!



由4段部件简易拼装而成



BOAT SPECIFICATIONS

MODEL: 产品型号:
54604

NAME: 名称:
Winpab Boat

Dimension: 船体尺寸:
L3.0m × W0.9m × H0.4m

Weight: 重量:
46kg

Max Load: 载重:
250kg

Trolling Motor Suggestion:
需另购推进器:
Item 50702/40Lbs (Not Included)

50702 MOTOR SPECIFICATIONS

Power of thrust: 峰值推力:
40Lbs

Max Voltage: 电压:
DC 12V

Power - Max: 功率:
500W

Amp - Max: 电流:
42A

Depth Adjustment: 深度调节:
Depth Collar

Prop Type: 螺旋桨型号:
2 blade prop 9inch diam

Prop Speed at Full Power: 转速:
Max. 1380 rpm underwater

Battery Type Required: 电池要求:
1x105AH deep cycle

Decibel Level (db): 噪音等级:
≤50db

Driving Type: 驱动模式:
5 Forward / 3 Reverse control

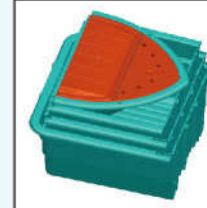

SMALL VOLUME
小体积拼装船

Only has small
volume while
unpacked.

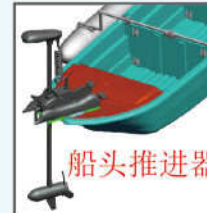

船头推进器

TROLLING MOTOR 1
可选配船头机(另购)

Bow Mount Trolling
Motor (not included)
can be used if
needed.



船尾推进器

TROLLING MOTOR 2
可选配船尾机(另购)

Transom Mount
Trolling Motor (not
included) can be
used if needed.



RETRACTABLE SIDE PODS
配置有双浮筒

2pcs side pods are
included: This
stability to allow
you stand up and
move about with
confidence when
stationary.



AIR PUMP
配置有充气泵

Air Pump is
included!

The new innovative Haswing Fishing Portable Assembly Boat, can be easily assembled by 4 Parts. It is required to utilise the electric trolling motor (not included). The boat is equipped with retractable side pods for stability, this allows you to stand up and move about with confidence when stationary. The boat can be both used bow mount trolling motor and transom mount trolling motor. Also the boat is equipped with stainless steel pod holders, air pump, aluminium seat cleat, 12pcs lock catch and much more!

All Propellers Here



MODEL:24000225
3-blade prop. / 9.3inch
Suitable for MODEL:
50700, 50703, 50704, 50706, 50716, 50720,
50736, 50739



MODEL:24001176
3-blade prop. / 10.7inch
Suitable for MODEL:
50719, 50749, 50752, 50756



MODEL:24001309
3-blade prop. / 9.3inch
Suitable for MODEL:
50744, 50745, 50762



MODEL:24000333
3-blade prop. / 11.8inch
Suitable for MODEL:
50713, 50727

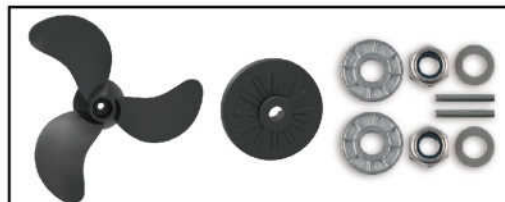

MODEL:24000318
3-blade prop. / 11.8inch
Suitable for MODEL:
50728



MODEL:24000825
2-blade prop. / 11.4inch
Suitable for MODEL:
50718D, 50721, 50722, 50737, 50738,
50742, 50743, 50755, 50757, 50758



MODEL:24000236
2-blade prop. / 9inch
Suitable for MODEL:
50701, 50702, 50708, 50714



MODEL:24000522
2-blade prop. / 5.9inch
Suitable for MODEL:
50735

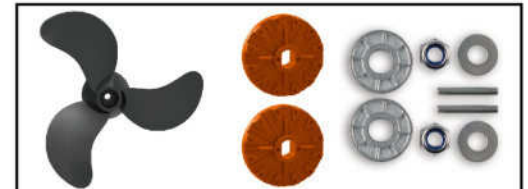

MODEL:24001357
3-blade prop. / 11.8inch
Suitable for MODEL:
50731, 50732, 50733, 50734



MODEL:24001273
3-blade prop. / 9.3inch
Suitable for MODEL:
50715, 50741

HASWING MOTOR Accessories Replacement Parts.

Full Range Supply



Wireless Foot Remote Controller
无线脚踏控制器



MODEL:50805
2.4GHz; LCD Display; With USB Charger;
3.7V/1100mAh Lipo battery included.
Suitable for MODEL:
50736, 50737, 50738

Wireless Remote Controller for GPS Items
无线遥控器(GPS)



MODEL:50806
2.4GHz; Bluetooth; Wifi;
3.7V/1100mAh Lipo battery included;
With USB Charger
Suitable for MODEL:
50736, 50737, 50738

Wireless Remote Controller
无线遥控器



MODEL:50802
433MHz; With USB Charger;
3.7V/200mAh Lipo battery included;
Suitable for MODEL:
50700, 50718D, 50706, 50757, 50758

DC Adapter 直流电源适配器



MODEL:59915
Input Voltage:8-15V; Output Voltage:5V,
Output Current:1.2A Max.
Suitable for MODEL:
50802, 50802N, 50805, 50805N, 50806,
50806N and Smartphone

Charging Example!



Display Metal Stand
推进器展示架



MODEL:59904
Material:Steel
Size:40cmX50cmX85cm
Suitable for MODEL:
most of HASWING electric motors

Quick Release Bracket
快拆板



MODEL:59906
Suitable for MODEL:
50700, 50718D, 50720, 50721, 50722, 50736,
50737, 50738, 50739, 50742, 50743

CONTENT

- Quick release bracket
- TMGX30
- 88 M6
- TMGX60
- Center Puck
- Bracket Bolt

Sacrificial Anode A
牺牲阳极 A



MODEL:59907
Φ10mm hole, easily-consumed spare parts
Suitable for MODEL:
most of HASWING electric motors

Sacrificial Anode B
牺牲阳极 B



MODEL:59908
Φ8mm hole, easily-consumed spare parts
Suitable for MODEL:
most of HASWING electric motors

Sacrificial Anode C
牺牲阳极 C



MODEL:59909
easily-consumed spare parts
Suitable for MODEL: 51200 only.

Sparking Plug
火花塞



MODEL:59910
easily-consumed spare parts
Suitable for MODEL: 51200 only.

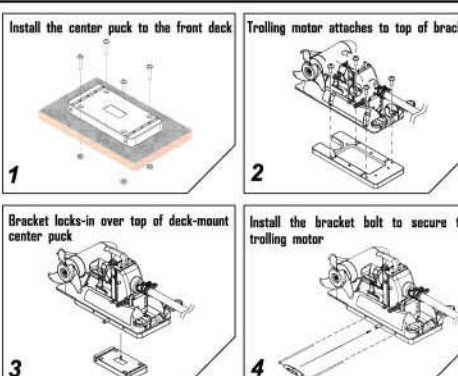

Full Range Supply



Simple Function Fishing Rod Holder
固定式鱼竿固定器



MODEL:54700
Only to be fixed a board.
Suitable for MODEL:
54601, 54602, 54603 and others.

Multi Function Fishing Rod Holder
多用途鱼竿固定器



MODEL:54701
Can be fixed to a board/a pole or a pipe.
Suitable for MODEL:
54601, 54602, 54603 and others.

Water Pump
独木舟排水泵



MODEL:54705
DC 12V/1.6A
Can drain away the water easily.
Suitable for MODEL: 54601, 54603

Magnetic Kill Switch
紧急停止开关



MODEL:24000392
Available
Suitable for MODEL:
50719, 50729, 50731, 50732, 50733, 50734,
50741, 50749, 50752, 50756

Kill Switch
熄火拉绳



MODEL:59911
Available
Suitable for MODEL: 51200 only.

Kill Switch
紧急停止拉索



MODEL:24000645
Available
Suitable for MODEL: 50713, 50728

Transformative Bracket
转换支架



MODEL:59913
Change the bow motor to transom motor.
Suitable for MODEL:
50736, 50737, 50738, 50739, 50742, 50743

60-Amp Clips
小鳄鱼夹



MODEL:59912
With higher amp rating.
Suitable for MODEL: Amp-Max.: 60A

120-Amp Clips
大鳄鱼夹



MODEL:59916
With higher amp rating.
Suitable for MODEL: Amp-Max.: 120A

40Lbs Electric Trolling Motor
电动推进器 (40磅)



MODEL:54704 **DD Brush Motor**
有刷直驱电机
Power of thrust : 40Lbs
Max Voltage : DC 12V
Power - Max : 500W
Amp - Max : 42A
Prop Type : 2 blade prop 9inch diam
Prop Speed at Full Power :
Max. 1380 rpm underwater
Battery Type Required:
1x105AH deep cycle
Weight : 5.5kg
Suitable for MODEL: 54601, 54602, 54603



汉飞动力



ZhongShan YaTai Electric Appliances Co., Ltd.

Add: No.4 XinLong Street, NanLong Industrial Park, SanXiang, ZhongShan, GuangDong Province, China

Postcode:528463

Email(Overseas Market): ye@haswing.com, daniel@haswing.com

Email(Chinese Market): wang1688@126.com, 304327713@qq.com

Tell: +86 760 8633 8326, +86 760 8669 2666

Fax: +86 760 8669 2996



9 580208 500003

WWW.HASWING.COM

www.zsyatai.en.alibaba.com