



QINGDAO SANTA INTERNATIONAL CO.,LTD



FRESH

FUTURE

SANTA

Your demand is where we start

Your satisfaction is our goal

More reliable products and
professional service is our way to achieve

To make life better is our mission



Group Profile

Santa Group has started the original production from year 2001 with headquarter in the beautiful costal city Qingdao City, Shandong Province, P. R. China. The group company consists of one export sales company, one domestic sales company and five subsidiary factories. In May of year 2013, Santa group merges and acquires China Manufacturing Solutions, which is one UK invested and a leading stainless steel fabrication specialist located in Weifang City, Shandong Province. As one of the largest and most professional refrigeration product Manufacturer, we mainly produce stainless steel cabinet, counter, saladette, VRX pizza display, blast freezer, storage chiller & freezer, backbar cooler, chest freezer, upright beverage cooler, independent island freezer, combined island freezer, commercial showcase, stainless steel fabrication and so on.

The group company covers 300,000 square meters with the annual production capacity 600,000 units. There are more than 1000 staffs in the group company, including 50 skilled technicians and engineers. The majority of the management have ever worked in the china top leading refrigeration manufacturing company and enjoy several ten years of refrigeration industry work experience. We have acquired the certificates of CE, CB, UL, GS, BRC, BSCI, ROHS, ISO9001 and ISO14001, while the products can reach European energy class A+, A++ and A+++ and American energy star. Santa Group own three brands including "Santa", "Little Duck" and "Haixue", which are recognized as the famous Chinese brands in the world's market.



Santa Group own three brands including "Santa", "Little Duck" and "Haixue", which are recognized as the famous Chinese brands in the world's market. Meantime, we also provide OEM and ODM service. We have succeeded to satisfy customers' request and develop many new series with high quality. Our products are widely accepted and highly approbated by customers from over 120 countries and regions, mainly from Europe, America, Middle East and Southeast Asia.

Insisting with the concept of "premium quality for premium life", Santa Group is ready to cooperate with customers from all over the world.



Production Line



Showroom



Certificate

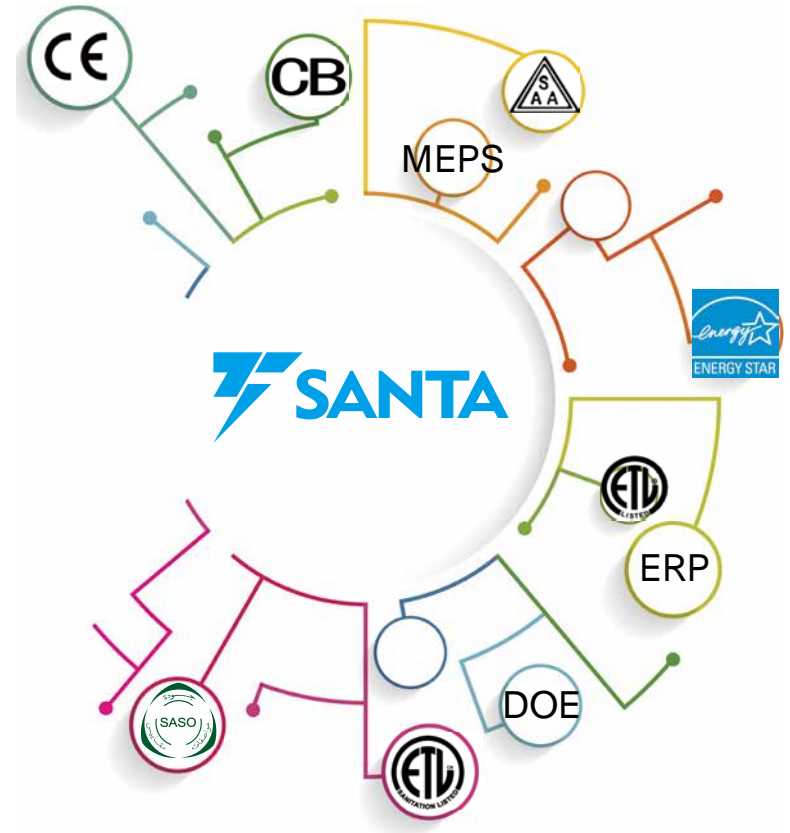

01 Kitchen Refrigeration

/012

- | European Cabinet-----P12-29
- | Counter-----P30-43
- | Saladette-----P44-53
- | Refrigerated Topping Unit-----P54-56
- | Blast Chiller-----P57
- | American Style-----P58-65
- | Bottle Cooler-----P66-67
- | Upright Chiller/freezer-----P68-71

02 Supermarket & Convenient Store Refrigeration

/075

- | Combinet Cabinet-----P75
- | Upright Cake Showcases-----P76-81
- | Multideck-Remote-----P82-83
- | Multideck-Plug In-----P84-85
- | Drinks Cabinet-----P86-89
- | Promotion Cabinet-----P90-91
- | Multideck-Plug In-----P92-100
- | Multideck-Remote-----P101-108,P110
- | Semi Cabinet-----P112-117
- | Island Freezer-----P118-131
- | Deli Counter-----P132-140
- | The Counter Cabinet-----P142-143
- | Cold Storage-----P145



03 Beverage Cooler

/148

- | Backbar-----P148-150
- | Beverage Cooler-----P151-159

04 Chest Freezer

/164

- | Glass Doors-----P164-169
- | Solid Doors-----P170-179
- | Spare Parts-----P180-181

05 Neutral Equipment

/184

- | Gastronorm Pan-----P184-187
- | Mini Kichten-----P188-189
- | Work Table-----P190
- | Cupboard-----P191
- | Trolley-----P192
- | Wall Shelves-----P193
- | Sink-----P194-195



KICHEN
REFRIGERATION

CABINET VENTILATED GN650 SERIES

CE



GN-650TN



Features

- European Fashionable style upright cabinet chiller
- Interior and exterior stainless steel AISI304 material for high level product
- Reversible doors and automatically self close when less than 90° open
- Inner box curved edges for easy cleaning
- Magnetic sealing strip keeps the cold air inside. Easy to remove without use of tools
- With Lock and key
- Digital thermostat Italian famous brand Dixell, Carel, Eliwell

- High quality compressor: Danfoss, Embraco
- LED light
- Germany Well-known brand EBM fans
- Compatible for GN2/1 Shelves
- Automatic defrost cooling system
- Replaceable door center sill with heating elements
- CFC free with 60mm super thickness
- Three layers of gray coated shelves per door as standard

Options

- Adjustable feet or Caster wheels

CABINET VENTILATED GN650 SERIES

CE



GN-650TNG



GN-650BTM



Product Model	GN-650TN/TNG	GN-650BT/BTG	GN-650TNM/TNMG	GN-650BTM/BTMG
Unit dimensions (W/D/H mm)	740*830*2010	740*830*2010	740*830*2010	740*830*2010
Net capacity (L)	650	650	638	638
Cooling system	Ventilated	Ventilated	Ventilated	Ventilated
Temperature (°C)	-2~+10	-18~-22	-2~+10	-18~-22
Shelves No.	3	3	3	3
Interior light	LED light	LED light	LED light	LED light
Compressor	Secop/Secop	Secop/Secop	Secop/Secop	Secop/Secop
Digital thermostat	Dixell	Dixell	Dixell	Dixell
Kind of coolant	R134a/R290	R404A/R290	R134a/R290	R404A/R290
40' Container loading	40	40	40	40

CABINET VENTILATED GN1410 SERIES



GN-1410BT

Features

- Two full size S/S door cabinet freezer
- Int&Ext material stainless steel
- Revisable self-closing door
- Full length stainless steel handle
- Digital thermostat
- With lock and key
- LED light
- Ventilated cooling
- Automatic defrost
- 6 adjustable GN2/1 Shelves
- CFC free foaming

Options

- Adjustable feet or Caster wheels



CABINET VENTILATED GN1410 SERIES



GN-1410TNM



GN-1410TNG

Product Model	GN-1410TN/TNG	GN-1410BT/BTG	GN-1410TNM/ TNMG	GN-1410BTM/ BTMG
Unit dimensions (W/D/H mm)	1480*830*2010	1480*830*2010	1480*830*2010	1480*830*2010
Net capacity (L)	1300	1300	1276	1276
Cooling system	Ventilated	Ventilated	Ventilated	Ventilated
Temperature (°C)	-2~+10	-18~-22	-2~+10	-18~-22
Shelves No.	6	6	6	6
Interior light	LED light	LED light	LED light	LED light
Compressor	Secop/Secop	Embraco	Secop/Secop	Embraco
Digital thermostat	Dixell	Dixell	Dixell	Dixell
Kind of coolant	R134a/R290	R404A	R134a/R290	R404A
40' Container loading	15	15	15	15

CABINET VENTILATED 700mm DEPTH



GN-580TN

Features

- European Fashionable style upright cabinet chiller
- Interior and exterior stainless steel AISI304 material for high level product
- Reversible doors and automatically self close when less than 90° open
- Inner box curved edges for easy cleaning
- Magnetic sealing strip keeps the cold air inside. Easy to remove without use of tools
- With Lock and key
- Digital thermostat Italian famous brand Dixell, Carel, Eliwell
- High quality compressor: Danfoss, Embraco
- LED light
- Germany Well-known brand EBM fans
- Automatic defrost cooling system
- Replaceable door center sill with heating elements
- CFC free with 60mm super thickness
- Three layers of gray coated shelves per door as standard

Options

- Adjustable feet or Caster wheels

Product Model	GN-580TN	GN-580BT
Unit dimensions (W/D/H mm)	740*730*2010	740*730*2010
Net capacity (L)	580	580
Cooling system	Ventilated	Ventilated
Temperature (°C)	-2~+10	-18~-22
Shelves No.	3	3
Interior light	LED light	LED light
Compressor	Secop/Secop	Secop/Secop
Digital thermostat	Dixell	Dixell
Kind of coolant	R134a/R290	R404A/R290
40' Container loading	45	45

CABINET VENTILATED 700mm DEPTH



GN-1180BT

Features

- Two full size S/S door cabinet freezer
- Int&Ext material stainless steel
- Reversible self-closing door
- Full length stainless steel handle
- Digital thermostat
- With lock and key
- LED light
- Ventilated cooling
- Automatic defrost
- 6 adjustable Shelves
- CFC free foaming

Options

- Adjustable feet or Caster wheels

Product Model	GN-1180TN	GN-1310TN	GN-1180BT	GN-1310BT
Unit dimensions (W/D/H mm)	1480*730*2010	1480*810*2010	1480*730*2010	1480*810*2010
Net capacity (L)	1180	1236	1180	1236
Cooling system	Ventilated	Ventilated	Ventilated	Ventilated
Temperature (°C)	-2~+10	-2~+10	-18~-22	-18~-22
Shelves No.	6	6	6	6
Interior light	LED light	LED light	LED light	LED light
Compressor	Secop/Secop	Embraco/Secop	Secop	Embraco/Secop
Digital thermostat	Dixell	Dixell	Dixell	Dixell
Kind of coolant	R134a/R290	R134a/R290	R404A	R404A
40' Container loading	22	22	22	22

CABINET VENTILATED FISH COOLER



GN-600TNF

Features

- One full size S/S solid door Cabinet fish cooler
- Int&Ext material stainless steel
- Reversible self-closing door
- Full length stainless steel handle
- Digital thermostat
- With lock and key
- LED light
- Fan cooling system
- 7 layers of pan inside
- CFC free foaming
- 60mm insulation thickness

Options

- Adjustable feet or Caster wheels
- Heating element for door frame



Product Model	GN-600TNF	GN-600TNV FISH	GN-600TNGV FISH
Unit dimensions (W/D/H mm)	680*810*2010	680*810*2010	680*810*2010
Net capacity (L)	600	600	600
Cooling system	Static with fan cooling	Ventilated	Ventilated
Temperature (°C)	0~+10	0~+10	0~+10
Shelves No.	7 layers of pan	7 layers of pan	7 layers of pan
Interior light	LED light	LED light	LED light
Compressor	ZEL/ZEL	ZEL/ZEL	ZEL/ZEL
Digital thermostat	Eliwell/Dixell	Eliwell/Dixell	Eliwell/Dixell
Kind of coolant	R134a/R600a	R134a/R600a	R134a/R600a
40' Container loading	42	42	42

CABINET GN600 SERIES



GN-600TN



GN-600TNG

Features

- Int&Ext material stainless steel
- Reversible self-closing door
- Full length stainless steel handle
- Digital thermostat
- With lock and key
- LED light
- Fan cooling system
- 3 adjustable GN2/1 Shelves
- CFC free foaming

Options

- Adjustable feet or Caster wheels
- Heating element for door frame

Product Model	GN-600TN	GN-600TNM	GN-600TNGM	GN-600TNG
Unit dimensions (W/D/H mm)	680*810*2010	680*810*2010	680*810*2010	680*810*2010
Net capacity (L)	600	600	600	600
Cooling system	Static with fan cooling	Static with fan cooling	Static with fan cooling	Static with fan cooling
Temperature (°C)	0~+10	0~+10	0~+10	0~+10
Shelves No.	3	3	3	3
Interior light	LED light	LED light	LED light	LED light
Compressor	ZEL/ZEL	ZEL/ZEL	ZEL/ZEL	ZEL/ZEL
Digital thermostat	Dixell	Dixell	Dixell	Dixell
Kind of coolant	R134a/R600a	R134a/R600a	R134a/R600a	R134a/R600a
40' Container loading	42	42	42	42

CABINET VENTILATED GN600 SERIES



GN-600TNV

GN-600BTMV

Features

- Int&Ext material stainless steel
- Revisable self-closing door
- Full length stainless steel handle
- Digital thermostat
- With lock and key
- LED light
- Ventilated cooling
- Automatic defrost
- 3 adjustable GN2/1 Shelves
- CFC free foaming

Options

- Adjustable feet or Caster wheels

Product Model	GN-600TNV/ GN-600TNGV	GN-600BTV	GN-600TNMV	GN-600BTMV
Unit dimensions (W/D/H mm)	680*810*2010	680*810*2010	680*810*2010	680*810*2010
Net capacity (L)	600	600	600	600
Cooling system	Ventilated	Ventilated	Ventilated	Ventilated
Temperature (°C)	-2~+10	-18~-22	-2~+10	-18~-22
Shelves No.	3	3	3	3
Interior light	LED light	LED light	LED light	LED light
Compressor	ZEL/ZEL	Embraco/Secop	ZEL/ZEL	Embraco/Secop
Digital thermostat	Dixell	Dixell	Dixell	Dixell
Kind of coolant	R134a/R600a	R404A/R290	R134a/R600a	R404A/R290
40' Container loading	42	42	42	42

CABINET GN1200 SERIES



GN-1200TN

GN-1200BTG

Features

- Int&Ext material stainless steel
- Digital thermostat
- With lock and key
- LED light
- Fan cooling system
- 6 adjustable GN2/1 Shelves
- CFC free foaming
- Auto defrosting and evaporation of condensation
- Self-closing door

Options

- Adjustable feet or Caster wheels

Product Model	GN-1200TN	GN-1200TNM	GN-1200TNG
Unit dimensions (W/D/H mm)	1340*810*2010	1340*810*2010	1340*810*2010
Net capacity (L)	1200	1200	1200
Cooling system	Static with fan cooling	Static with fan cooling	Static with fan cooling
Temperature (°C)	0~+10	0~+10	0~+10
Shelves No.	6	6	6
Interior light	LED light	LED light	LED light
Compressor	Secop/Secop	Secop/Secop	Secop/Secop
Digital thermostat	Dixell	Dixell	Eliwell/Dixell
Kind of coolant	R134a/R290	R134a/R290	R134a/R290
40' Container loading	22	22	22

CABINET VENTILATED GN1200 SERIES



GN-1200TNV



GN-1200TNMV

Features

- Int&Ext material stainless steel
- Full length stainless steel handle
- Digital thermostat
- With lock and key
- LED light
- Ventilated cooling
- Automatic defrost
- 6 adjustable GN2/1 Shelves
- CFC free foaming
- Auto defrosting and evaporation of condensation
- Self-closing door

Options

- Adjustable feet or Caster wheels

Product Model	GN-1200TNV	GN-1200BTV	GN-1200TNMV	GN-1200BTMV
Unit dimensions (W/D/H mm)	1340*810*2010	1340*810*2010	1340*810*2010	1340*810*2010
Net capacity (L)	1200	1200	1200	1200
Cooling system	Ventilated	Ventilated	Ventilated	Ventilated
Temperature (°C)	-2~+10	-18~-22	-2~+10	-18~-22
Shelves No.	6	6	6	6
Interior light	LED light	LED light	LED light	LED light
Compressor	Secop/Secop	Secop	Secop/Secop	Secop
Digital thermostat	Dixell	Dixell	Dixell	Dixell
Kind of coolant	R134a/R290	R404A	R134a/R290	R404A
40' Container loading	22	22	22	22

CABINET SNACK400 SERIES



SNACK-400TN



SNACK-400BTM

Features

- Int&Ext material stainless steel
- Full length stainless steel handle
- Digital thermostat
- With lock and key
- LED light
- Fan cooling system
- CFC free foaming
- 60mm insulation thickness
- Self-closing door

Options

- Adjustable feet or Caster wheels

Product Model	SNACK-400TN	SNACK-400TNM
Unit dimensions (W/D/H mm)	680*710*2010	680*710*2010
Net capacity (L)	429	429
Cooling system	Static with fan cooling	Static with fan cooling
Temperature (°C)	0~+10	0~+10
Shelves No.	3	3
Interior light	LED light	LED light
Compressor	ZEL/ZEL	ZEL/ZEL
Digital thermostat	Dixell	Dixell
Kind of coolant	R134a/R600a	R134a/R600a
40' Container loading	48	48

CABINET SNACK400S SERIES



SNACK-400STN



SNACK-400STNG

Features

- Bottom Engine Room
- Int&Ext material stainless steel
- Revisable self-closing door
- Digital thermostat
- With lock and key
- LED light
- Fan cooling system
- CFC free foaming
- 60mm insulation thickness
- Auto defrosting and evaporation of condensation
- Self-closing door

Options

- Adjustable feet or Caster wheels
- Heating element for door frame

Product Model	SNACK-400STN	SNACK-400STNG
Unit dimensions (W/D/H mm)	680*710*2010	680*710*2010
Net capacity (L)	429	429
Cooling system	Static with fan cooling	Static with fan cooling
Temperature (°C)	0~+10	0~+10
Shelves No.	3	3
Interior light	LED light	LED light
Compressor	ZEL/ZEL	ZEL/ZEL
Digital thermostat	Dixell	Dixell
Kind of coolant	R134a/R600a	R134a/R600a
40' Container loading	48	48

CABINET VENTILATED SNACK400 SERIES



SNACK-400TNV



SNACK-400BTMV

Features

- Int&Ext material stainless steel
- Revisable self-closing door
- Full length stainless steel handle
- Digital thermostat
- With lock and key
- LED light
- Ventilated cooling
- Automatic defrost
- CFC free foaming
- 60mm insulation thickness
- Self-closing door

Options

- Adjustable feet or Caster wheels

Product Model	SNACK-400TNV/ SNACK-400TNGV	SNACK- 400BTV	SNACK- 400TNMV	SNACK- 400BTMV
Unit dimensions (W/D/H mm)	680*710*2010	680*710*2010	680*710*2010	680*710*2010
Net capacity (L)	429	429	429	429
Cooling system	Ventilated	Ventilated	Ventilated	Ventilated
Temperature (°C)	-2~+10	-18~-22	-2~+10	-18~-22
Shelves No.	3	3	3	3
Interior light	LED light	LED light	LED light	LED light
Compressor	ZEL/ZEL	Embraco/Secop	ZEL/ZEL	Embraco/ Secop
Digital thermostat	Dixell	Dixell	Dixell	Dixell
Kind of coolant	R134a/R600a	R404A/R290	R134a/R600a	R404A/R290
40' Container loading	48	48	48	48

CABINET SNACK800 SERIES

CE



SNACK-800TN

SNACK-800BTG

Features

- Int&Ext material stainless steel
- Revisable self-closing door
- With Temper glass door
- Digital thermostat
- With lock and key
- LED light
- Fan cooling system
- CFC free foaming
- 60mm insulation thickness

Options

- Adjustable feet or Caster wheels

Product Model	SNACK-800TN	SNACK-800TNG
Unit dimensions (W/D/H mm)	1340*710*2010	1340*710*2010
Net capacity (L)	1065	1065
Cooling system	Static with fan cooling	Static with fan cooling
Temperature (°C)	0~+10	0~+10
Shelves No.	6	6
Interior light	LED light	LED light
Compressor	Secop/Secop	Secop/Secop
Digital thermostat	Dixell	Dixell
Kind of coolant	R134a/R290	R134a/R290
40' Container loading	25	25

CABINET VENTILATED SNACK800 SERIES

CE



SNACK-800TNV

SNACK-800TNMV

Features

- Int&Ext material stainless steel
- Revisable self-closing door
- Full length stainless steel handle
- Digital thermostat
- With lock and key
- LED light
- Ventilated cooling
- Automatic defrost
- CFC free foaming
- 60mm insulation thickness

Options

- Adjustable feet or Caster wheels
- Defrost heating tube for evaporator

Product Model	SNACK-800TNV	SNACK-800BTV	SNACK-800TNMV	SNACK-800BTMV
Unit dimensions (W/D/H mm)	1340*710*2010	1340*710*2010	1340*710*2010	1340*710*2010
Net capacity (L)	1065	1065	1065	1065
Cooling system	Ventilated	Ventilated	Ventilated	Ventilated
Temperature (°C)	-2~+10	-18~-22	-2~+10	-18~-22
Shelves No.	6	6	6	6
Interior light	LED light	LED light	LED light	LED light
Compressor	Secop/Secop	Secop	Secop/Secop	Secop
Digital thermostat	Dixell	Dixell	Dixell	Dixell
Kind of coolant	R134a/R290	R404A	R134a/R290	R404A
40' Container loading	25	25	25	25

CABINET VENTILATED BAKERY SERIES



PA-800TN

Features

- One full size S/S solid door bakery cabinet chiller
- Int&Ext material stainless steel
- Revisable self-closing door
- Full length stainless steel handle
- Digital thermostat
- With lock and key
- LED light
- Ventilated cooling
- Automatic defrost
- 10 adjustable Bakery 600*800 pan Support
- CFC free foaming
- 60mm insulation thickness

Options

- Adjustable feet or Caster wheels

Product Model	PA-800TN	PA-800BT
Unit dimensions (W/D/H mm)	740*990*2010	740*990*2010
Net capacity (L)	737	737
Cooling system	Ventilated	Ventilated
Temperature (°C)	-2~+10	-18~-22
Interior light	LED light	LED light
Compressor	Secop/Secop	Secop
Digital thermostat	Dixell	Dixell
Kind of coolant	R134a/R290	R404A
40' Container loading	33	33

CABINET VENTILATED BAKERY SERIES



GE-800BT

Features

- One full size S/S solid door bakery cabinet freezer
- Int&Ext material stainless steel
- Revisable self-closing door
- Full length stainless steel handle
- Digital thermostat
- With lock and key
- LED light
- Ventilated cooling
- Automatic defrost
- 10 adjustable Bakery 600*800 Shelves,no GN pans
- CFC free foaming
- 60mm insulation thickness

Options

- Adjustable feet or Caster wheels

Product Model	GE-800TN	GE-800BT
Unit dimensions (W/D/H mm)	740*990*2010	740*990*2010
Net capacity (L)	737	737
Cooling system	Ventilated	Ventilated
Temperature (°C)	-2~+10	-18~-22
Shelves No.	/	10
Interior light	LED light	LED light
Compressor	Secop/Secop	Secop
Digital thermostat	Dixell	Dixell
Kind of coolant	R134a/R290	R404A
40' Container loading	33	33

COUNTER



GN-4180TN

Features

- European Fashionable style counter chiller/freezer
- Inside and outside stainless steel 304 material for high level product
- Reversible doors and automatically self close when less than 90° open
- Inner box curved edges for easy cleaning
- Magnetic sealing strip keeps the cold air inside. Easy to remove without use of tools
- Digital thermostat Eliwell, Dixell, Carel
- High quality famous compressor: Danfoss, Embraco,
- Fans: Germany Well-known brand EBM fans
- Compatible for GN1/1 Shelves
- Automatic defrost cooling system
- Replaceable door center sill with heating elements
- CFC free with 60mm super thickness
- One layer of gray coated shelves per door as standard
- Adjustable stainless steel feet or lockable castors
- Special various front panel design according to customer request
- Optional glass doors/with GN1/3,GN2/3,GN1/2 Drawers/ SS 201 materia/lock and key / internal light/engine room drawer/with splashback

COUNTER
VENTILATED GN SERIES

GN-2100TN



GN-3100TN



GN-4100BT

Features

- Int&Ext material stainless steel
- Revisable self-closing door
- Full length stainless steel handle
- Digital thermostat
- Ventilated cooling
- Automatic defrost

Options

- Adjustable feet or Caster wheels
- With GN1/3,GN2/3,GN1/2 Drawers
- Internal LED light

Product Model	GN-2100TN	GN-2100BT	GN-3100TN	GN-3100BT	GN-4100TN	GN-4100BT
Unit dimensions (W/D/H mm)	1360*700*850	1360*700*850	1795*700*850	1795*700*850	2230*700*850	2230*700*850
Net capacity (L)	282	282	417	417	553	553
Cooling system	Ventilated	Ventilated	Ventilated	Ventilated	Ventilated	Ventilated
Temperature (°C)	-2~+10	-18~-22	-2~+10	-18~-22	-2~+10	-18~-22
Shelves No.	2	2	3	3	4	4
Interior light	Option	Option	Option	Option	Option	Option
Compressor	ZEL/ZEL	Secop/Secop	ZEL/ZEL	Secop/Secop	Secop/Secop	Secop/Secop
Digital thermostat	Dixell	Dixell	Dixell	Dixell	Dixell	Dixell
Kind of coolant	R134a/R600a	R404a/R290	R134a/R600a	R404a/R290	R134a/R290	R404a/R290
40' Container loading	48	48	38	38	32	32

COUNTER VENTILATED GN SERIES



GN-4200BT



GN-2200TN

Features

- Int&Ext material stainless steel
- Revisable self-closing door
- Full length stainless steel handle
- Digital thermostat
- Ventilated cooling
- Automatic defrost

Options

- Adjustable feet or Caster wheels
- with GN1/3,GN2/3,GN1/2 Drawers
- Internal LED light

Product Model	GN-2200TN	GN-2200BT	GN-3200TN	GN-3200BT	GN-4200TN	GN-4200BT
Unit dimensions (W/D/H mm)	1360*700*950	1360*700*950	1795*700*950	1795*700*950	2230*700*950	2230*700*950
Net capacity (L)	282	282	417	417	553	553
Cooling system	Ventilated	Ventilated	Ventilated	Ventilated	Ventilated	Ventilated
Temperature (°C)	-2~+10	-18~-22	-2~+10	-18~-22	-2~+10	-18~-22
Shelves No.	2	2	3	3	4	4
Interior light	Option	Option	Option	Option	Option	Option
Compressor	ZEL/ZEL	Secop/Secop	ZEL/ZEL	Secop/Secop	Secop/Secop	Secop/Secop
Digital thermostat	Dixell	Dixell	Dixell	Dixell	Dixell	Dixell
Kind of coolant	R134a/ R600a	R404A/R290	R134a/ R600a	R404A/R290	R134a/R290	R404A/R290
40' Container loading	48	48	38	38	32	32

COUNTER VENTILATED GN SERIES



GN-2100TNG



GN-3100TNG



GN-4200BTG

Features

- Int&Ext material stainless steel
- Revisable self-closing door
- Full length stainless steel handle
- Digital thermostat
- Interior light
- Ventilated cooling
- Automatic defrost

Options

- Adjustable feet or Caster wheels
- with GN1/3,GN2/3,GN1/2 Drawers
- Internal LED light

Product Model	GN-2100TNG	GN-2100BTG	GN-3100TNG	GN-3100BTG	GN-4100TNG	GN-4100BTG
Unit dimensions (W/D/H mm)	1360*700*850	1360*700*850	1795*700*850	1795*700*850	2230*700*850	2230*700*850
Net capacity (L)	282	282	417	417	553	553
Cooling system	Ventilated	Ventilated	Ventilated	Ventilated	Ventilated	Ventilated
Temperature (°C)	-2~+10	-18~-22	-2~+10	-18~-22	-2~+10	-18~-22
Shelves No.	2	2	3	3	4	4
Interior light	Yes	Yes	Yes	Yes	Yes	Yes
Compressor	ZEL/ZEL	Secop/Secop	ZEL/ZEL	Secop/Secop	Secop/Secop	Secop/Secop
Digital thermostat	Dixell	Dixell	Dixell	Dixell	Dixell	Dixell
Kind of coolant	R134a/R600a	R404A/R290	R134a/R600a	R404A/R290	R134a/R290	R404A/R290
40' Container loading	48	48	38	38	32	32

COUNTER VENTILATED SNACK SERIES



SNACK-2100TN



SNACK-3100TN



SNACK-4100BT

Features

- Snackcounter with 600mm depth
- Int&Ext material stainless steel
- Revisable self-closing door
- Full length stainless steel handle
- Digital thermostat
- Ventilated cooling
- Automatic defrost

Options

- Adjustable feet or Caster wheels
- with GN1/3,GN2/3,GN1/2 Drawers
- Internal LED light

Product Model	SNACK-2100TN	SNACK-2100BT	SNACK-3100TN	SNACK-3100BT	SNACK-4100TN	SNACK-4100BT
Unit dimensions (W/D/H mm)	1360*600*850	1360*600*850	1795*600*850	1795*600*850	2230*600*850	2230*600*850
Net capacity (L)	228	228	339	339	449	449
Cooling system	Ventilated	Ventilated	Ventilated	Ventilated	Ventilated	Ventilated
Temperature (°C)	-2~+10	-18~-22	-2~+10	-18~-22	-2~+10	-18~-22
Shelves No.	2	2	3	3	4	4
Interior light	Option	Option	Option	Option	Option	Option
Compressor	ZEL/ZEL	Secop/Secop	ZEL/ZEL	Secop/Secop	Secop/Secop	Secop/Secop
Digital thermostat	Dixell	Dixell	Dixell	Dixell	Dixell	Dixell
Kind of coolant	R134a/R600a	R404a/R290	R134a/R600a	R404a/R290	R134a/R290	R404a/R290
40" Container loading	48	48	38	38	32	32

COUNTER VENTILATED SNACK SERIES



SNACK-2100TNG



SNACK-3100TNG



SNACK-4100TNG

Features

- Snackcounter with 600mm depth
- Int&Ext material stainless steel
- Revisable self-closing door
- Full length stainless steel handle
- Digital thermostat
- Interior light
- Ventilated cooling
- Automatic defrost

Options

- Adjustable feet or Caster wheels
- with GN1/3,GN2/3,GN1/2 Drawers
- Internal LED light
- Lock and key
- With Splashback

Product Model	SNACK-2100TNG	SNACK-3100TNG	SNACK-4100TNG
Unit dimensions (W/D/H mm)	1360*600*850	1795*600*850	2230*600*850
Net capacity (L)	228	339	449
Cooling system	Ventilated	Ventilated	Ventilated
Temperature (°C)	-2~+10	-2~+10	-2~+10
Shelves No.	2	3	4
Interior light	Yes	Yes	Yes
Compressor	ZEL/ZEL	ZEL/ZEL	Secop/Secop
Digital thermostat	Dixell	Dixell	Dixell
Kind of coolant	R134a/R600a	R134a/R600a	R404a/R290
40" Container loading	48	38	32

QINGDAO SANTA INTERNATIONAL CO.,LTD

UNDERCOUNTER VENTILATED UNDER COUNTER

CE



U-GN4100TN

Features

- Undercounter with 650mm height
- Int&Ext material stainless steel
- Revisable self-closing door
- Full length stainless steel handle
- Digital thermostat
- Ventilated cooling
- Automatic defrost



U-GN3160TN

Options

- Adjustable feet or Caster wheels

Product Model	U-GN2100TN	U-GN3100TN	U-GN4100TN
Unit dimensions (W/D/H mm)	1360*700*650	1795*700*650	2230*700*650
Net capacity (L)	214	317	420
Cooling system	Ventilated	Ventilated	Ventilated
Temperature (°C)	-2~+10	-2~+10	-2~+10
Shelves No.	2	3	4
Interior light	Option	Option	Option
Compressor	ZEL/ZEL	ZEL/ZEL	Secop/Secop
Digital thermostat	Dixell	Dixell	Dixell
Kind of coolant	R134a/R600a	R134a/R600a	R404A/R290
40' Container loading	72	54	48

www.santagroup.com.cn info@santagroup.com.cn

QINGDAO SANTA INTERNATIONAL CO.,LTD

UNDERCOUNTER VENTILATED UNDER COUNTER

CE



U-GN4100BT

Features

- Undercounter with 650mm height
- Int&Ext material stainless steel
- Revisable self-closing door
- Full length stainless steel handle
- Digital thermostat
- Ventilated cooling
- Automatic defrost



U-GN3160BT

Options

- Adjustable feet or Caster wheels

Product Model	U-GN2100BT	U-GN3100BT	U-GN4100BT
Unit dimensions (W/D/H mm)	1360*700*650	1795*700*650	2230*700*650
Net capacity (L)	214	317	420
Cooling system	Ventilated	Ventilated	Ventilated
Temperature (°C)	-18~-22	-18~-22	-18~-22
Shelves No.	2	3	4
Interior light	Option	Option	Option
Compressor	ZEL/ZEL	ZEL/ZEL	Secop/Secop
Digital thermostat	Dixell	Dixell	Dixell
Kind of coolant	R134a/R600a	R134a/R600a	R404A/R290
40' Container loading	72	54	48

www.santagroup.com.cn info@santagroup.com.cn

COUNTER VENTILATED TOP GLASS SERIES



GN-3100SALGC

Features

- Three S/S solid door counter chiller
- Open top with curved glass door cover
- Int&Ext material stainless steel
- Revisable self-closing door
- Full length stainless steel handle
- Digital thermostat
- Ventilated cooling
- Automatic defrost
- 3 adjustable GN1/1 Shelves
- CFC free foaming
- R134a refrigerant
- 230V 50HZ

Options

- Adjustable feet or Caster wheels
- Internal LED light
- Lock and key



Product Model	GN-2100SALGC	GN-3100SALGC	GN-4100SALGC
Unit dimensions (W/D/H mm)	1360*740*1365	1795*740*1365	2230*740*1365
Net capacity (L)	314	465	616
Cooling system	Ventilated	Ventilated	Ventilated
Temperature (°C)	+4~+10	+4~+10	+4~+10
Shelves No.	2	3	4
Interior light	Option	Option	Option
Compressor	ZEL/ZEL	ZEL/ZEL	Secop/Secop
Digital thermostat	Dixell	Dixell	Dixell
Kind of coolant	R134a/R600a	R134a/R600a	R404A/R290
40' Container loading	48	38	32

COUNTER VENTILATED TOP GLASS SERIES



GN-3100SALSQ

Features

- Three S/S solid door counter chiller
- Open top with flat glass door cover
- Int&Ext material stainless steel
- Revisable self-closing door
- Full length stainless steel handle
- Digital thermostat
- Ventilated cooling
- Automatic defrost
- 3 adjustable GN1/1 Shelves
- CFC free foaming
- R134a refrigerant
- 230V 50HZ

Options

- Adjustable feet or Caster wheels
- Internal LED light
- Lock and key



Product Model	GN-2100SALSQ	GN-3100SALSQ	GN-4100SALSQ
Unit dimensions (W/D/H mm)	1360*740*1365	1795*740*1365	2230*740*1365
Net capacity (L)	314	465	616
Cooling system	Ventilated	Ventilated	Ventilated
Temperature (°C)	+4~+10	+4~+10	+4~+10
Shelves No.	2	3	4
Interior light	Option	Option	Option
Compressor	ZEL/ZEL	ZEL/ZEL	Secop/Secop
Digital thermostat	Dixell	Dixell	Dixell
Kind of coolant	R134a/R600a	R134a/R600a	R404A/R290
40' Container loading	48	38	32

COUNTER VENTILATED BAKERY COUNTER



PA-2100TN



PA-3100TN

Features

- Two S/S solid door PA counter chiller
- PA BakeryCounter with 800mm depth
- Int&Ext material stainless steel
- Revisable self-closing door
- Full length stainless steel handle
- Digital thermostat
- Ventilated cooling
- Automatic defrost
- 2 adjustable Shelves

Options

- Adjustable feet or Caster wheels
- Internal LED light
- Lock and key

Product Model	PA-2100TN	PA-3100TN
Unit dimensions (W/D/H mm)	1510*800*850	2020*800*850
Net capacity (L)	390	580
Cooling system	Ventilated	Ventilated
Temperature (°C)	-2~+10	-2~+10
Shelves No.	2	3
Interior light	Option	Option
Compressor	ZEL/ZEL	Secop/Secop
Digital thermostat	Dixell	Dixell
Kind of coolant	R134a/R600a	R134a/R290
40' Container loading	30	28

COUNTER VENTILATED BAKERY COUNTER



SH-2000/700



SH-3000/800

Features

- Counter chiller with 700mm depth
- Compatible 7"GN1/3 pans on Prep-top
- Int&Ext material stainless steel
- Revisable self-closing door
- Full length stainless steel handle
- Digital thermostat
- Ventilated cooling
- Automatic defrost

Options

- Adjustable feet or Caster wheels
- Internal LED light
- Lock and key
- GN1/4,GN1/6 Top



Product Model	SH-2000/700	SH-2000/800	SH-3000/700	SH-3000/800
Unit dimensions (W/D/H mm)	1360*700*1085	1510*800*1085	1795*700*1085	2020*800*1085
Net capacity (L)	282	390	417	580
Cooling system	Ventilated	Ventilated	Ventilated	Ventilated
Temperature (°C)	-2~+10	-2~+10	-2~+10	-2~+10
Shelves No.	2	2	3	3
Interior light	Option	Option	Option	Option
Compressor	ZEL/ZEL	ZEL/ZEL	Secop/Secop	Secop/Secop
Digital thermostat	Dixell	Dixell	Dixell	Dixell
Kind of coolant	R134a/R600a	R134a/R600a	R134a/R290	R134a/R290
40' Container loading	48(HQ)	30(HQ)	38(HQ)	28(HQ)

COUNTER VENTILATED PIZZA COUNTER

CE



PZ-2600TN+VRX1500/380



PZ-1610TN+VRX1500/380

Features

- Pizza counter with VRX on the top
- Granite table top
- With 7 multi functional set of guides
- Int&Ext material stainless steel
- Reversible self-closing door
- Full length stainless steel handle
- Digital thermostat
- Ventilated cooling
- Automatic defrost

Options

- Adjustable feet or Caster wheels
- Internal LED light
- Lock and key

Product Model	PZ-2600TN	VRX-1500/380	PZ-1610TN	VRX-1500/380
Unit dimensions (W / D/ H mm)	1510*800*1000	1500*395*435	1510*800*1000	1500*395*435
Net capacity (L)	390	GN1/3*5+GN1/2*1	390	GN1/3*5+GN1/2*1
Cooling system	Ventilated	Static	Ventilated	Static
Temperature (°C)	-2~+10	0~+10	-2~+10	0~+10
Shelves No.	2	/	2	/
Interior light	Option	/	Option	/
Compressor	ZEL/ZEL	ZEL/ZEL	ZEL/ZEL	ZEL/ZEL
Digital thermostat	Dixell	Dixell	Dixell	Dixell
Kind of coolant	R134a/R600a	R134a/R600a	R134a/R600a	R134a/R600a
40" Container loading	30	261	30	261

COUNTER VENTILATED PIZZA COUNTER

CE



PZ-2610TN+VRX2000/380



PZ-3600TN+VRX2000/380

Features

- Pizza counter with VRX on the top
- Granite table top
- With 7 drawers for storage
- Int&Ext material stainless steel
- Reversible self-closing door
- Full length stainless steel handle
- Digital thermostat
- Ventilated cooling
- Automatic defrost

Options

- Adjustable feet or Caster wheels
- Internal LED light
- Lock and key

Product Model	PZ-3600TN	VRX-2000/380	PZ-2610TN	VRX-2000/380
Unit dimensions (W / D/ H mm)	2020*800*1000	2000*395*435	2025*800*1000	2000*395*435
Net capacity (L)	580	GN1/3*9	580	GN1/3*9
Cooling system	Ventilated	Static	Ventilated	Static
Temperature (°C)	-2~+10	0~+10	-2~+10	0~+10
Shelves No.	3	/	2	/
Interior light	Option	/	Option	/
Compressor	Secop/Secop	ZEL/ZEL	Secop/Secop	ZEL/ZEL
Digital thermostat	Dixell	Dixell	Dixell	Dixell
Kind of coolant	R134a/R290	R134a/R600a	R134a/R290	R134a/R600a
40" Container loading	28	196	28	196

SALADETTE



S-900SQ

Features

- European standard two door saladette
- Interior and exterior stainless steel AISI304 material for high level product
- Inner box curved edges for easy cleaning
- Magnetic sealing strip keeps the cold air inside. Easy to remove
- Without use of tools
- Digital thermostat Italian famous brand Dixell, Carel, Eliwell
- High quality famous compressor: Embraco, Zanussi
- Compatible for 2*GN1/1 pans and 3*gn1/6 pans
- 2*GN1/1 shelves
- Fan cooling system or Ventilated cooling
- CFC free foaming
- R134a/R600a
- Adjustable feet or small caster wheels



S-900

Options

- Ventilated cooling system/ glass doors/ SS 201 material



S-903 6D

SALADETTE VENTILATED COOLING



SF-900

Features

- New Ventilated cooling Saladette
- Finned Evaporator with assisted fan inside the inner box
- Interior and exterior stainless steel AISI304 material for high level product
- Inner box curved edges for easy cleaning
- Magnetic sealing strip keeps the cold air inside. Easy to remove without use of tools
- Digital thermostat Italian famous brand Dixell, Carel, Eliwell
- High quality famous compressor: Embraco, Zanussi
- GN1/1 shelves
- Fan assisted cooling system
- CFC free foaming
- R134a/R600a
- Adjustable feet or small caster wheels



SF-903

Options

- Ventilated cooling system/glass doors/ SS 201 material

Product Model	SF-900	SF-903
Unit dimensions (W / D/ H mm)	900*740*850	1365*740*850
Net capacity (L)	240	368
Cooling system	Ventilated	Ventilated
Temperature (°C)	+4--+10	+4--+10
Shelves No.	2	3
Compressor	ZEL/ZEL	Secop/Secop
Digital thermostat	Dixell	Dixell
Kind of coolant	R134a/R600a	R134a/R290
40' Container loading	72	48

SALADETTE

CE



S-450



S-900



S-903

Features

- European standard saladette
- Interior and exterior stainless steel AISI304 material for high level product
- Inner box curved edges for easy cleaning
- Magnetic sealing strip keeps the cold air inside. Easy to remove without use of tools
- Digital thermostat Italian famous brand Dixell,Carel,Eliwell
- High quality famous compressor: Embraco,Zanussi
- Compatible for GN1/1 pans and GN1/6 pans
- GN1/1 shelves
- Fan cooling system
- CFC free foaming
- R134a/R600a
- Adjustable feet or small caster wheels

Options

- Ventilated cooling system/glass doors/ SS 201 material

Product Model	S-450	S-900	S-903
Unit dimensions (W / D/ H mm)	450*700*850	900*700*850	1365*700*850
Net capacity (L)	108	240	368
Cooling system	Static with fan cooling	Static with fan cooling	Static with fan cooling
Temperature (°C)	0~+10	0~+10	0~+10
Shelves No.	1	2	3
Compressor	ZEL	ZEL/ZEL	Secop/Secop
Digital thermostat	Dixell	Dixell	Dixell
Kind of coolant	R600a	R134a/R600a	R134a/R290
40' Container loading	150	72	48

SALADETTE

CE



S-901



S-901 2D



S-901 4D

Features

- Saladette with stainless steel table top with GN1/2 Drawer
- Interior and exterior stainless steel AISI304 material for high level product
- Inner box curved edges for easy cleaning
- Magnetic sealing strip keeps the cold air inside. Easy to remove without use of tools
- Digital thermostat Italian famous brand Dixell,Carel,Eliwell
- High quality famous compressor: Embraco, Zanussi
- GN1/1 Shelves+ GN1/2 Drawer
- Fan assited cooling system
- CFC free foaming
- R134a/R600a
- Adjustable feet or small caster wheels

Options

- Ventilated cooling system/glass doors/ SS 201 material

Product Model	S-901	S-901-2D	S-901-4D
Unit dimensions (W / D/ H mm)	900*700*850	900*700*850	900*700*850
Net capacity (L)	240	230	220
Cooling system	Static with fan cooling	Static with fan cooling	Static with fan cooling
Temperature (°C)	0~+10	0~+10	0~+10
Shelves No.	2	1 plus 2 Drawers GN1/2	4 Drawers GN1/2
Compressor	ZEL/ZEL	ZEL/ZEL	ZEL/ZEL
Digital thermostat	Dixell	Dixell	Dixell
Kind of coolant	R134a/R600a	R134a/R600a	R134a/R600a
40' Container loading	72	72	72

SALADETTE



S-903S/S TOP

Features

- Three s/s solid door Saladette with stainless steel table top
- Interior and exterior stainless steel AISI304 material for high level product
- Inner box curved edges for easy cleaning
- Magnetic sealing strip keeps the cold air inside. Easy to remove without use of tools
- Digital thermostat Italian famous brand Dixell, Carel, Eliwell
- High quality famous compressor: Embraco, Zanussi
- 3*GN1/1 shelves
- Fan assisted cooling system

Options

- Ventilated cooling system/glass doors/ SS 201 material/R290 New Refrigerant



S-903 6D

Features

- Saladette with stainless steel table top with 6*GN1/2 Drawer
- Interior and exterior stainless steel AISI304 material for high level product
- Inner box curved edges for easy cleaning
- Magnetic sealing strip keeps the cold air inside. Easy to remove without use of tools
- Digital thermostat Italian famous brand Dixell, Carel, Eliwell
- High quality famous compressor: Embraco, Zanussi
- 6*GN1/2 Drawer
- Fan assisted cooling system

Options

- Ventilated cooling system/glass doors/ SS 201 material

Product Model	S-903 S/S TOP	S-903-6D
Unit dimensions (W / D/ H mm)	1365*700*850	1365*700*850
Net capacity (L)	368	368
Cooling system	Static with fan cooling	Static with fan cooling
Temperature (°C)	0~+10	0~+10
Shelves No.	3	6 Drawers GN1/2
Compressor	Secop/Secop	Secop/Secop
Digital thermostat	Dixell	Dixell
Kind of coolant	R134a/R290	R134a/R290
40' Container loading	48	48

SALADETTE



PS-200

Features

- Two s/s solid door Saladette with Pre- top
- Refrigerated topping well for 5*GN1/6 Pans
- Interior and exterior stainless steel AISI304 material for high level product
- Inner box curved edges for easy cleaning
- Magnetic sealing strip keeps the cold air inside. Easy to remove without use of tools
- Digital thermostat Italian famous brand Dixell, Carel, Eliwell
- High quality famous compressor: Embraco, Zanussi
- 2*GN1/1 shelves
- Fan assisted cooling system

Options

- Ventilated cooling system/glass doors/ SS 201 material/R290 New Refrigerant



PS-300

Features

- Three s/s solid door Saladette with Pre- top
- Refrigerated topping well for 8*GN1/6 Pans
- Interior and exterior stainless steel AISI304 material for high level product
- Inner box curved edges for easy cleaning
- Magnetic sealing strip keeps the cold air inside. Easy to remove without use of tools
- Digital thermostat Italian famous brand Dixell, Carel, Eliwell
- High quality famous compressor: Embraco, Zanussi
- 3*GN1/1 shelves
- Fan assisted cooling system

Options

- Ventilated cooling system/glass doors/ SS 201 material

Product Model	PS-200	PS-300
Unit dimensions (W / D/ H mm)	900*700*970	1365*700*970
Net capacity (L)	240	392
Cooling system	Static with fan cooling	Static with fan cooling
Temperature (°C)	0~+10	0~+10
Shelves No.	2	3
Compressor	ZEL/ZEL	Secop/Secop
Digital thermostat	Dixell	Dixell
Kind of coolant	R134a/R600a	R134a/R290
40' Container loading	72	48

SALADETTE



PS-900

Features

- Two s/s solid door Saladette with Granite top
- Refrigerated topping well for 5*GN1/6 Pans
- Interior and exterior stainless steel AISI304 material for high level product
- Inner box curved edges for easy cleaning
- Magnetic sealing strip keeps the cold air inside. Easy to remove without use of tools
- Digital thermostat Italian famous brand Dixell,Carel,Eliwell
- High quality famous compressor:Embraco, Zanussi
- 2*GN1/1 shelves
- Fan assisted cooling system

Options

- Ventilated cooling system/ glass doors/ SS 201 material/ R290 New Refrigerant



PS-903

Features

- Three s/s solid door Saladette with Granite top
- Refrigerated topping well for 8*GN1/6 Pans
- Interior and exterior stainless steel AISI304 material for high level product
- Inner box curved edges for easy cleaning
- Magnetic sealing strip keeps the cold air inside.Easy to remove without use of tools
- Digital thermostat Italian famous brand Dixell,Carel,Eliwell
- High quality famous compressor: Embraco,Zanussi
- 3*GN1/1 shelves
- Fan assisted cooling system

Options

- Ventilated cooling system/ glass doors/ SS 201 material

Product Model	PS-900	PS-903
Unit dimensions (W/D/H mm)	900*700*1075	1365*700*1075
Net capacity (L)	240	402
Cooling system	Static with fan cooling	Static with fan cooling
Temperature (°C)	0~+10	0~+10
Shelves No.	2	3
Compressor	ZEL/ZEL	Secop/Secop
Digital thermostat	Dixell	Dixell
Kind of coolant	R134a/R600a	R134a/R290
40' Container loading	72	48(HQ)

SALADETTE



S-903 PZ+VRX1400/330

Features

- Three s/s solid door Saladette with Granite top
- Interior and exterior stainless steel AISI304 material for high level product
- Inner box curved edges for easy cleaning
- Magnetic sealing strip keeps the cold air inside. Easy to remove without use of tools
- Digital thermostat Italian famous brand Dixell,Carel,Eliwell
- High quality famous compressor: Embraco, Zanussi
- 3*GN1/1 shelves
- Fan assisted cooling system
- CFC free foaming
- R134a/R600a
- Adjustable feet or small caster wheels



Options

- Ventilated cooling system/glass doors/ SS 201 material

Product Model	S-903PZ	VRX-1400/330
Unit dimensions (W/D/H mm)	1400*700*1020	1400*335*435
Net capacity (L)	368	GN1/4*6
Cooling system	Static with fan cooling	Static
Temperature (°C)	0~+10	0~+10
Shelves No.	3	2
Compressor	Secop/Secop	ZEL/ZEL
Digital thermostat	Eliwell/Dixell	Dixell
Kind of coolant	R134a/R290	R134a/R600a
40' Container loading	48(HQ)	343

SALADETTE



S-900CG

Features

- Two s/s solid door Saladette with curved glass cover
- Open top suitable for 2*GN1/1 pans and 3*GN1/6 Pans
- Interior and exterior stainless steel AISI304 material for high level product
- Inner box curved edges for easy
- Magnetic sealing strip keeps the cold air inside. Easy to remove without use of tools
- Digital thermostat Italian famous brand Dixell,Carel,Eliwell
- High quality famous compressor: Embraco,Zanussi
- 2*GN1/1 shelves
- Fan assisted cooling system

Options

- Ventilated cooling system/ glass doors/ SS 201 material/ R290 New Refrigerant



S-903SQ

Features

- Three s/s solid door saladette with squared glass cover
- Open top suitable for 4*GN1/1 pans
- Interior and exterior stainless steel AISI304 material for high level product
- Inner box curved edges for easy cleaning
- Magnetic sealing strip keeps the cold air inside. Easy to remove without use of tools
- Digital thermostat Italian famous brand Dixell,Carel,Eliwell
- High quality famous compressor: Embraco, Zanussi
- 3*GN1/1 shelves
- Fan assisted cooling system
- CFC free foaming

Options

- Ventilated cooling system/ glass doors/ SS 201 material/ R290 New Refrigerant

Product Model	S-900SQ	S-903SQ	S-900CG	S-903CG
Unit dimensions (W/D/H mm)	900*700*850	1365*700*850	900*700*850	1365*700*850
Net capacity (L)	240	368	240	368
Cooling system	Static with fan cooling	Static with fan cooling	Static with fan cooling	Static with fan cooling
Temperature (°C)	0~+10	0~+10	0~+10	0~+10
Shelves No.	2	3	2	3
Compressor	ZEL/ZEL	Secop/Secop	ZEL/ZEL	Secop/Secop
Digital thermostat	Dixell	Dixell	Dixell	Dixell
Kind of coolant	R134a/R600a	R134a/R290	R134a/R600a	R134a/R290
40' Container loading	72	48	72	48

SALADETTE



S-902

Features

- Two s/s solid door saladette with top compatible for 3*GN1/1 Pan
- Interior and exterior stainless steel AISI304 material for high level product
- Inner box curved edges for easy cleaning
- Magnetic sealing strip keeps the cold air inside. Easy to remove without use of tools
- Digital thermostat Italian famous brand Dixell,Carel,Eliwell
- High quality famous compressor: Embraco, Zanussi
- 2*GN1/1 Shelves
- Fan assisted cooling system
- CFC free foaming
- R134a/R600a
- Adjustable feet or small caster wheels

Options

- Ventilated cooling system/glass doors/ SS 201 material/R290 New Refrigerant



Product Model	S-902
Unit dimensions (W/D/H mm)	1045*700*850
Net capacity (L)	302
Cooling system	Static with fan cooling
Temperature (°C)	0~+10
Shelves No.	2
Compressor	ZEL/ZEL
Digital thermostat	Dixell
Kind of coolant	R134a/R600a
40' Container loading	60

REFRIGERATED TOPPING UNIT



VRX-2000/330

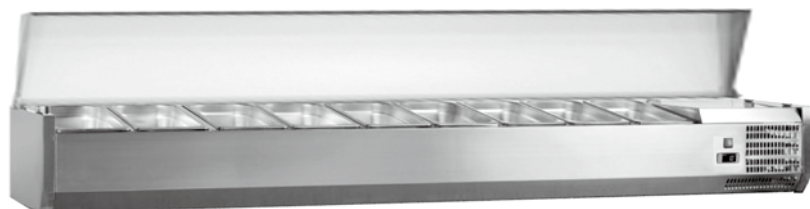

VRX-2000/380S/S LID

Product Model	VRX-1200/330	VRX-1400/330	VRX-1500/330	VRX-1600/330	VRX-1800/330
Unit dimensions (W/D/H mm)	1200*335*435	1400*335*435	1500*335*435	1600*335*435	1800*335*435
Net capacity (L)	GN1/4*5	GN1/4*6	GN1/4*7	GN1/4*8	GN1/4*9
Cooling system	Static	Static	Static	Static	Static
Temperature (°C)	0~+10	0~+10	0~+10	0~+10	0~+10
Compressor	ZEL/ZEL	ZEL/ZEL	ZEL/ZEL	ZEL/ZEL	ZEL/ZEL
Digital thermostat	Dixell	Dixell	Dixell	Dixell	Dixell
Kind of coolant	R134a/R600a	R134a/R600a	R134a/R600a	R134a/R600a	R134a/R600a
40' Container loading	386	336	310	294	260

REFRIGERATED TOPPING UNIT

Features

- European standard refrigerated topping unit
- Interior and exterior stainless steel AISI304 material for high level product
- Digital thermostat Italian famous brand Dixell, Carel, Eliwell
- High quality famous compressor: Embraco,Zanussi
- Accept GN1/4 pans for 330 range and GN1/3 pans for 380 range
- CFC free foaming
- R134a/R600a
- Adjustable feet
- Optional: top stainless steel cover/ SS 201 material/R290 New Refrigerant

330 SERIES

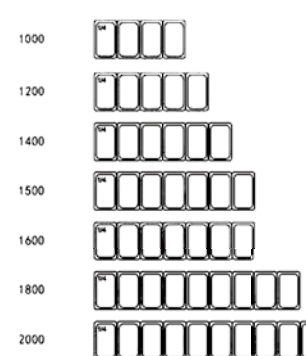

380 SERIES



VRX-2000/330	VRX-1200/380	VRX-1400/380	VRX-1500/380	VRX-1600/380	VRX-1800/380	VRX-2000/380
2000*335*435	1200*395*435	1400*395*435	1500*395*435	1600*395*435	1800*395*435	2000*395*435
GN1/4*10	GN1/3*3+GN1/2*1	GN1/3*4+GN1/2*1	GN1/3*5+GN1/2*1	GN1/3*7	GN1/3*8	GN1/3*9
Static	Static	Static	Static	Static	Static	Static
0~+10	0~+10	0~+10	0~+10	0~+10	0~+10	0~+10
ZEL/ZEL	ZEL/ZEL	ZEL/ZEL	ZEL/ZEL	ZEL/ZEL	ZEL/ZEL	ZEL/ZEL
Dixell	Dixell	Dixell	Dixell	Dixell	Dixell	Dixell
R134a/R600a	R134a/R600a	R134a/R600a	R134a/R600a	R134a/R600a	R134a/R600a	R134a/R600a
242	323	280	261	247	218	196

REFRIGERATED TOPPING UNIT



Features

- Interior and exterior stainless steel material for high level product
- High quality famous compressor: Zanussi
- Accept GN1/6 pans range
- CFC free foaming
- R134a/R600a
- Adjustable feet
- exclusive sales in the United States and Canada

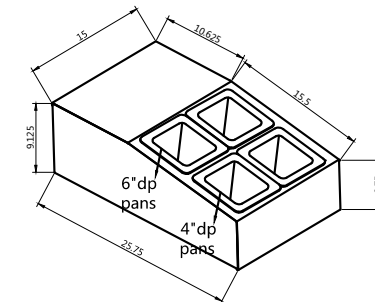
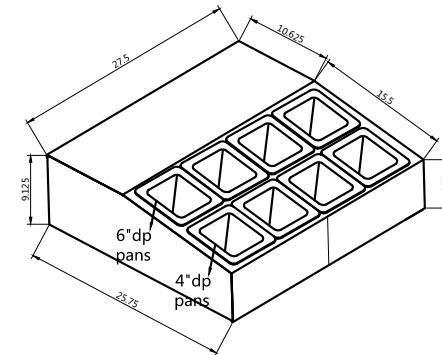

Product Model	RTR-4	RTR-8
Interna Dimension(W/D/H mm)	300*145*156	624*145*156
External Dimension WITH WEELS(W/D/H mm)	379*656*236	699*656*236
Packing Dimension(W/D/H mm)	450*715*380	770*715*380
Refrigerant	R600a	R600a
Net Volume	GN1/6*4	GN1/6*8
Cooling system	static	static
Temperature Control	Mechanical thermostat	Mechanical thermostat
Compressor standard	ZEL	ZEL
Temperature(°C)	0-10	0-10
40' Container loading	560	336

REACH-IN



ST-23BR

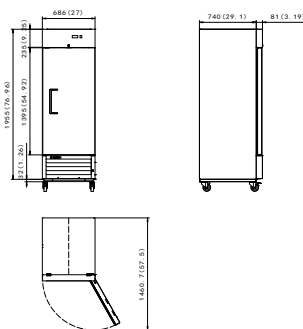

ST-23BR&ST23BF

Features

- American fashionable style upright cabinet chiller/freezer
- Exterior material SS430, interior Pre-coated Aluminum
- Reversible doors and automatically self close when less than 90° open
- Inner box curved edges for easy cleaning
- Magnetic sealing strip keeps the cold air inside. Easy to remove without use of tools
- With Lock and key
- Digital thermostat Italian famous brand Dixell,Carel,Eliwell
- High quality famous compressor: Embraco
- Internal LED light



ST-49BR



ST-72BR

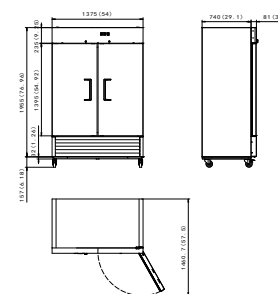

ST-49BR&ST49BF

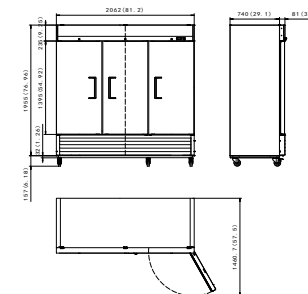

ST-72BR&ST72BF

Manufacturer Code	ST-23BR	ST-23BF	ST-49BR	ST-49BF	ST-72BR	ST-72BF
Unit dimensions (W/D/H inch)	27"×32"×83.5"	27"×32"×83.5"	54.1"×32"×83.5"	54.1"×32"×83.5"	81.2"×32.1"×83.3"	81.2"×32.2"×83.3"
Packing imensions (W/D/H inch)	28.3"×33"×84.6"	28.3"×33"×84.6"	55.7"×33"×84.6"	55.7"×33"×84.6"	82.3"×33"×84.6"	82.3"×33"×84.6"
Net capacity (CFT)	23	23	49	49	72	72
Cooling system	Ventilated	Ventilated	Ventilated	Ventilated	Ventilated	Ventilated
Climate class	N	N	N	N	N	N
Kind of coolant	R134a/R290	R404A/R290	R134a/R290	R404A/R290	R134a/R290	R404A/R290
Voltage / frequency (V/Hz)	115/60	115/60	115/60	115/60	115/60	115/60
Compressor	Embraco	Embraco	Embraco	Embraco/Secop	Embraco/Secop	Embraco/Secop
Temperature (°F)	+33~+41	-10~+10	33~41	-10~+10	33~41	-10~+10
Number of shelf	3	3	6	6	9	9
Interior light	LED	LED	LED	LED	LED	LED
Digital thermostat	Dixell/Eliwell	Dixell/Eliwell	Dixell/Eliwell	Dixell/Eliwell	Dixell/Eliwell	Dixell/Eliwell
40 °HC Container load	39	39	21	21	13	13

REACH-IN



ST-23BRG

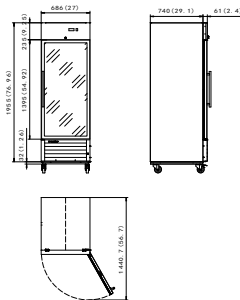

ST-23BRG&ST-23BFG



Features

- American fashionable style upright cabinet chiller/freezer
- Exterior material SS430, interior Pre-coated Aluminum
- Reversible doors and automatically self close when less than 90° open
- Inner box curved edges for easy cleaning
- Magnetic sealing strip keeps the cold air inside. Easy to remove without use of tools
- With Lock and key
- Digital thermostat Italian famous brand Dixell,Carel,Eliwell
- High quality famous compressor: Embraco
- Internal LED light



ST-49BRG



ST-72BRG

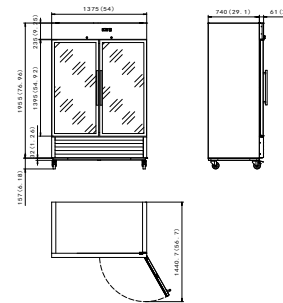

ST-49BRG&ST-49BFG

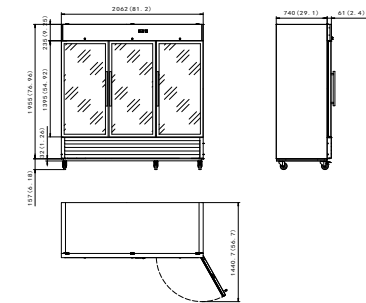

ST-72BRG&ST-72BFG

Manufacturer Code	ST-23BRG	ST-23BFG	ST-49BRG	ST-49BFG	ST-72BRG	ST-72BFG
Unit dimensions (W/D/H inch)	27"*32"*83.5"	27"*32"*83.5"	54.1"*32"*83.5"	54.1"*32"*83.5"	81.2"*32.1"*83.3"	81.2"*32.1"*83.3"
Packing ensions (W/D/H inch)	28.3"*33"*84.6"	28.3"*33"*84.6"	55.7"*33"*84.6"	55.7"*33"*84.6"	82.3"*33"*84.6"	82.3"*33"*84.6"
Door Type	Glass	Glass	Glass	Glass	Glass	Glass
Cooling system	Ventilated	Ventilated	Ventilated	Ventilated	Ventilated	Ventilated
Climate class	N	N	N	N	N	N
Voltage / frequency (V/Hz)	115/60	115/60	115/60	115/60	115/60	115/60
Compressor	Embraco	Embraco	Embraco	Embraco/Secop	Embraco/Secop	Embraco/Secop
Temperature (°F)	33~41	-10~+10	33~41	-10~+10	33~41	-10~+10
Interior light	LED	LED	LED	LED	LED	LED
Digital thermostat	Dixell/Eliwell	Dixell/Eliwell	Dixell/Eliwell	Dixell/Eliwell	Dixell/Eliwell	Dixell/Eliwell
Number of shelf	3	3	6	6	9	9
Kind of coolant	R134a/R290	R404A/R290	R134a/R290	R404A/R290	R134a/R290	R404A/R290
40 'HC Container load	39	39	21	21	13	13

UNDER-COUNTER



TUC-29R



TUC-60R

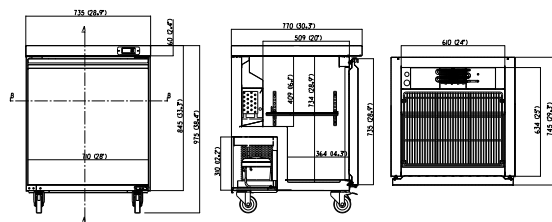

TUC-29R

Features

- American fashionable style counter
- Exterior material SS430, interior Pre-coated Aluminum
- Reversible doors and automatically self close when less than 90° open
- Inner box curved edges for easy cleaning
- Magnetic sealing strip keeps the cold air inside. Easy to remove without use of tools
- With Lock and key
- Digital thermostat Italian famous brand Dixell, Carel, Eliwell
- High quality famous compressor: Embraco
- Internal LED light

Options

- Fans: Germany Well-known brand EBM fans
- Automatic defrost cooling system
- Adjustable stainless steel feet or lockable castors
- Special various front panel design according to customer request

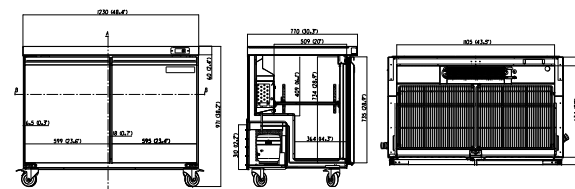

TUC-48R

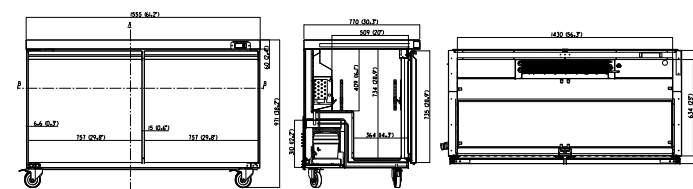

TUC-60R

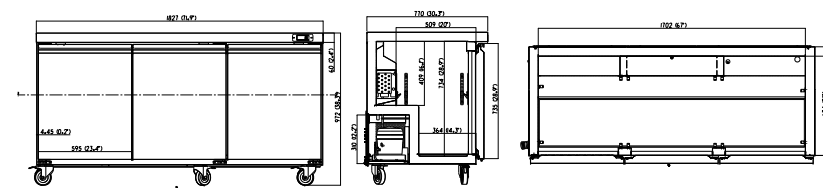

TUC-72R

Product Model	TUC-29R	TUC-48R	TUC-60R	TUC-72R
Unit dimensions (W/D/H inch)	29"×30.3"×38.3"	48"×30.3"×38.3"	61"×30.3"×38.3"	72"×30.3"×38.3"
Packing dimensions (W/D/H inch)	31"×33.9"×40.7"	50"×33.9"×40.7"	63"×33.9"×40.7"	74"×33.9"×40.7"
Net volume cu ft	6.7ft3	11.1ft3	14.1ft3	16.6ft3
Temperature (F)	33~41	33~41	33~41	33~41
Compressor	Secop	Secop	Secop	Secop
Refrigerant	R290	R290	R290	R290
Cooling system	Ventilated	Ventilated	Ventilated	Ventilated
Interior light	LED	LED	LED	LED
Digital thermostat	Dixell	Dixell	Dixell	Dixell
Doors	1	2	2	3
Voltage/Frequency(V/Hz)	115/60	115/60	115/60	115/60
Condenser fan	EBM	EBM	EBM	EBM
40 °C Container load	84	46	28	28

UNDER-COUNTER



TUC-29F



TUC-60F

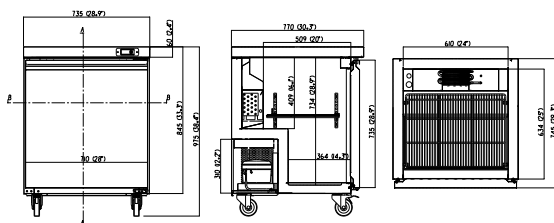

TUC-29F

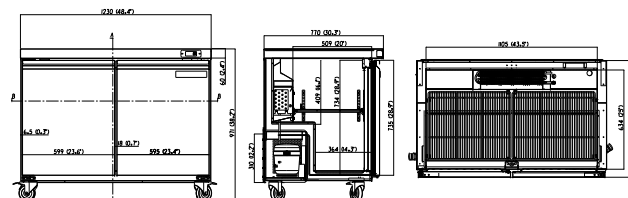

TUC-48F

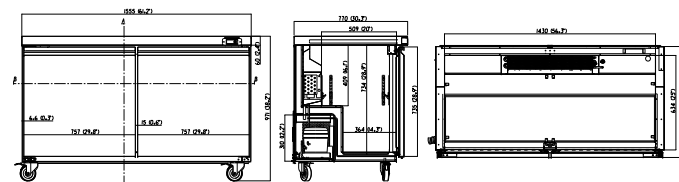

TUC-60F

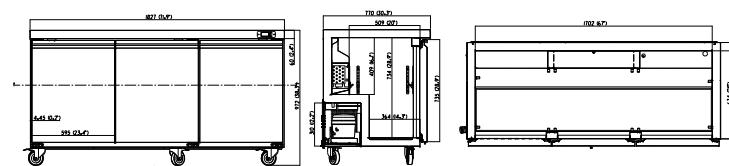

TUC-72F

Features

- American fashionable style counter
- Exterior material SS430, interior Pre-coated Aluminum
- Reversible doors and automatically self close when less than 90°open
- Inner box curved edges for easy cleaning
- Magnetic sealing strip keeps the cold air inside. Easy to remove without use of tools
- With Lock and key
- Digital thermostat Italian famous brand Dixell, Carel, Eliwell
- High quality famous compressor: Embraco
- Internal LED light

Options

- Fans: Germany Well-known brand EBM fans
- Automatic defrost cooling system
- Adjustable stainless steel feet or lockable castors
- Special various front panel design according to customer request

Product Model	TUC-29F	TUC-48F	TUC-60F	TUC-72F
Unit dimensions (W/D/H inch)	29"×30.3"×38.3"	48"×30.3"×38.3"	61"×30.3"×38.3"	72"×30.3"×38.3"
Packing dimensions (W/D/H inch)	31"×33.9"×40.7"	50"×33.9"×40.7"	63"×33.9"×40.7"	74"×33.9"×40.7"
Net volume cu ft	6.7ft3	11.1ft3	14.1ft3	16.6ft3
Temperature (F)	-10~10	-10~10	-10~10	-10~10
Compressor	Secop	Secop	Secop	Secop
Refrigerant	R290	R290	R290	R290
Cooling system	Ventilated	Ventilated	Ventilated	Ventilated
Interior light	LED	LED	LED	LED
Digital thermostat	Dixell	Dixell	Dixell	Dixell
Doors	1	2	2	3
Voltage/Frequency(V/Hz)	115/60	115/60	115/60	115/60
Condenser fan	EBM	EBM	EBM	EBM
40'HC Container load	84	46	28	28

PREP TABLE



TPP-94

Features

- American fashionable style Saladette
- Exterior material SS430, interior Pre-coated Aluminum
- Reversible doors and automatically self close when less than 90° open
- Inner box curved edges for easy cleaning
- Magnetic sealing strip keeps the cold air inside. Easy to remove without use of tools
- With Lock and key
- Digital thermostat Italian famous brand Dixell, Carel, Eliwell
- High quality famous compressor: Embraco
- Internal LED light

Options

- Fans: Germany Well-known brand EBM fans
- Automatic defrost cooling system
- Adjustable stainless steel feet or lockable castors

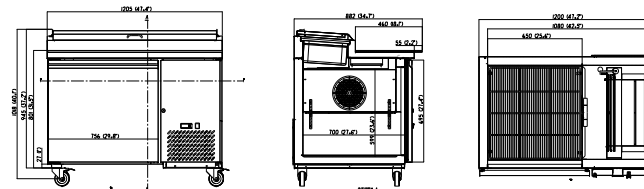

TPP-47

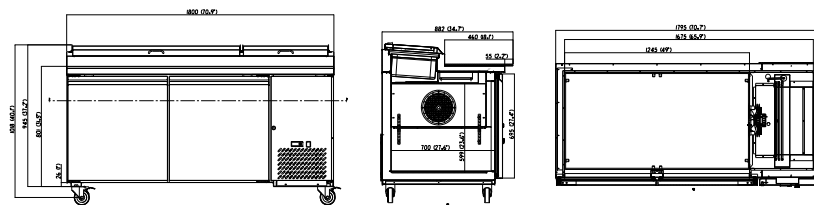

TPP-67

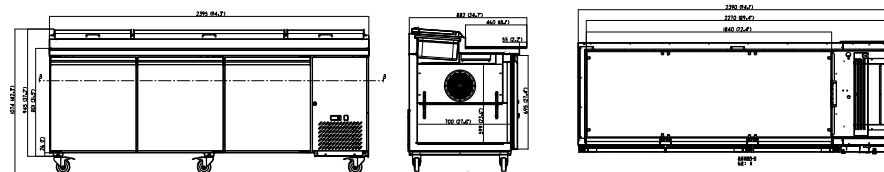

TPP-94

Product Model	TPP-47	TPP-67	TPP-94
Unit Dimensions (W/D/H inch)	49"×38.2"×44.4"	73"×38.2"×44.4"	96"×38.2"×44.4"
Packing Dimensions (W/D/H inch)	47"×34.6"×42"	71"×34.6"×42"	94"×34.6"×42"
Net Volume cu ft	10.95ft3	20.91ft3	30.87ft3
Temperature Range (F)	33~41	33~41	33~41
Compressor	SECOP	SECOP	SECOP
Refrigerant	R290	R290	R290
Cooling System	Ventilated	Ventilated	Ventilated
light	LED	LED	LED
Digital thermostat	Dixell	Dixell	Dixell
Doors	1	2	3
Voltage/Frequency(V/Hz)	115/60	115/60	115/60
Condenser Fan	EBM	EBM	EBM
40 °HC Container load	42	26	16

SANDWICH TABLE



TSSU-72



TSSU-72

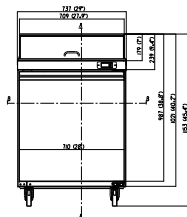

TSSU-29

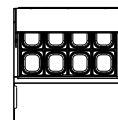
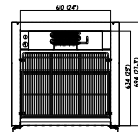
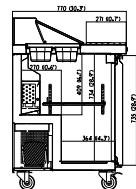

Features

- American fashionable style Saladette
- Exterior material SS430, interior Pre-coated Aluminum
- Reversible doors and automatically self close when less than 90° open
- Inner box curved edges for easy cleaning
- Magnetic sealing strip keeps the cold air inside. Easy to remove without use of tools
- With Lock and key
- Digital thermostat Italian famous brand Dixell, Carel, Eliwell
- High quality famous compressor: Embraco
- Internal LED light

Options

- Fans: Germany Well-known brand EBM fans
- Automatic defrost cooling system
- Adjustable stainless steel feet or lockable castors

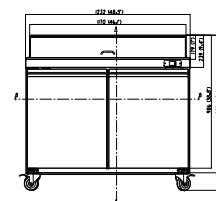

TSSU-48

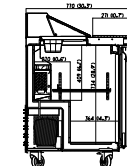

TSSU-60

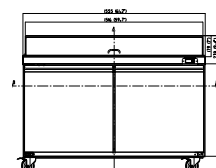
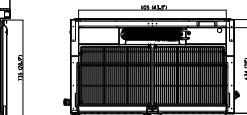

TSSU-72

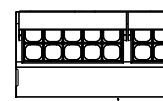
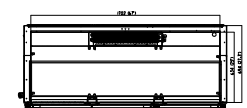
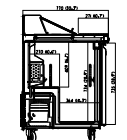
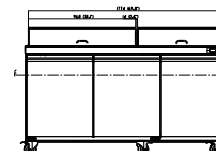
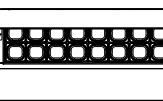
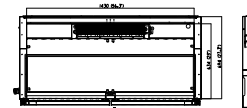
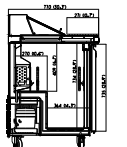

Product Model	TSSU-29	TSSU-48	TSSU-60	TSSU-72
Unit dimensions (W/D/H inch)	29"×30.3"×45.4"	48.4"×30.3"×45.4"	61.2"×30.3"×45.4"	72"×30.3"×45.4"
Packing dimensions (W/D/H inch)	31"×33.9"×47.8"	50.4"×33.9"×47.8"	63"×33.9"×47.8"	74"×33.9"×47.8"
Net volume cu ft	7.59ft3	13.77ft3	17.83ft3	21.22ft3
Temperature (F)	33~41	33~41	33~41	33~41
Compressor	SECOP	SECOP	SECOP	SECOP
Refrigerant	R290	R290	R290	R290
Cooling system	Ventilated	Ventilated	Ventilated	Ventilated
Interior light	LED	LED	LED	LED
Digital thermostat	Dixell	Dixell	Dixell	Dixell
Doors	1	1	2	3
Voltage/Frequency(V/Hz)	115/60	115/60	115/60	115/60
Condenser fan	EBM	EBM	EBM	EBM
40 'HC Container load	84	46	28	28

DIRECT BOTTLE COOLER



BC-15

Features

- Roll-bond evaporator with internal fan
- Compressor cycle defrost
- Digital thermostat
- Suitable for tall bottles as wine or spirits
- Free standing or built-in possibility of use



Product Model	BC-10	BC-15	BC-20
Unit dimensions (W/D/H mm)	1000*577*850	1500*577*850	2000*577*850
Packing dimensions (W/D/H mm)	1040*607*1010	1540*607*1010	2040*607*1010
Cooling system	Static	Static	Static
Freezer Temperature	0~6°C	0~6°C	0~6°C
Total net capacity	248L	410L	560L
Defrosting	Manual	Manual	Manual
Kind of coolant	R600a	R600a	R600a
Cooling system	ZEL	ZEL	ZEL
Door (lid) Number	1 (fixed)+ 2(silding)	1 (fixed)+ 3(silding)	1 (fixed)+ 4(silding)
Divider	1/Gray	2Gray	3/Gray
Defrost drain	with	with	with
Interior light	Without	Without	Without
Adjustable thermostat	digital(dixell)	digital(dixell)	digital(dixell)
40' Container load(pic)	82	52	38

ECONOMIC DIRECT BOTTLE COOLER



BD-300P

Features

- Outside PCM, inside white pre-painted aluminium sheet
- Super low energy consumption
- 60mm thickness insulation
- Suitable for wide climate, SN/T
- Defrost water drain hole
- Adjustable feet
- Environmentally friendly
- Available in white or silver body color



Product Model	BD-300P
Unit dimensions (W/D/H mm)	1035*680*855
Packing dimensions (W/D/H mm)	1080*780*890
Cooling system	Static
Climate class	N
Freezer Temperature	-5~8°C
Total net capacity	188L
Defrosting	Manual
Kind of coolant	R600a
Compressor	LG
Door (lid) Number	1 (fixed)+2(silding)
Number of shelves	NO
Adjustable thermostat	Mechanical with digital thermometer
40' HC Container load (pic)	96

UPRIGHT CHILLER/FREEZER



SR-20S

SR-40

SR-60

Features

- European standard white pre-painted solid door upright chiller/freezer
- Digital Thermostat
- Lock and key
- Fan assisted cooling system
- Reversible self-closing door
- Roll bond plate with fan for chiller
- 7 layer of evaporator as shelves for freezer
- Two front adjustable feet, two rear wheels

Options

- Outside stainless steel material or glass
- Eliwell / Dixell

Product Model	SR-20	SR-40	SR-40V	SR-60	SR-60V
Unit dimensions (W/D/H mm)	595*653*870	595*653*1840	595*653*1840	775*723*1840	775*723*1840
Net capacity (L)	170	380	380	590	590
Cooling system	Static	Static with fan cooling	Ventilated	Static with fan cooling	Ventilated
Temperature (°C)	0~+8	0~+8	0~+8	0~+8	0~+8
Shelves No.	1+1	3+1	3+1	3+1	3+1
Interior light	Yes	Yes	Yes	Yes	Yes
Compressor	ZEL/ZEL	ZEL/ZEL	ZEL/ZEL	ZEL/ZEL	ZEL/ZEL
Digital thermostat	Dixell	Dixell	Dixell	Dixell	Dixell
Kind of coolant	R134a/R600a	R134a/R600a	R134a/R600a	R134a/R600a	R134a/R600a
40' Container loading	108	54	54	42	42

UPRIGHT CHILLER/FREEZER



SF-20

SF-40VS

SF-40V

Features

- European standard white pre-painted solid door upright chiller/freezer
- Digital Thermostat
- Lock and key
- Fan assisted cooling system
- Reversible self-closing door
- Roll bond plate with fan for chiller
- 7 layer of evaporator as shelves for freezer
- Two front adjustable feet, two rear wheels

Options

- Outside stainless steel material/Eliwell / Dixell

Product Model	SF-20	SF-40	SF-40V	SF-60	SF-60V
Unit dimensions (W/D/H mm)	595*653*870	595*653*1840	595*653*1840	775*723*1840	775*723*1840
Net capacity (L)	170	380	380	590	590
Cooling system	Static	Ventilated	Ventilated	Ventilated	Ventilated
Temperature (°C)	-18~-22	-18~-22	-18~-22	-18~-22	-18~-22
Shelves No.	1+1	6+1	6+1	6+1	6+1
Interior light	Yes	Yes	Yes	Yes	Yes
Compressor	ZEL/ZEL	Embraco/ZEL	Embraco/ZEL	Embraco/ZEL	Embraco/ZEL
Digital thermostat	Dixell/Elitech	Dixell/Elitech	Dixell/Elitech	Dixell/Elitech	Dixell/Elitech
Kind of coolant	R134a/R600a	R404a/R290	R404a/R290	R404a/R290	R404a/R290
40' Container loading	108	54	54	42	42

UPRIGHT CHILLER/FREEZER



SR-20G



SR-40G

Features

- European standard glass door upright chiller
- Digital Thermostat
- Lock and key
- Fan assisted cooling system
- Reversible self-closing door
- Roll bond plate with fan
- Two front adjustable feet, two rear wheels

Options

- Outside door stainless steel material or white pre-painted steel
- Eliwell / Dixell

Product Model	SR-20G	SF-40VG	SR-40G	SR-40VG
Unit dimensions (W/D/H mm)	595*653*870	595*653*1840	595*653*1840	595*653*1840
Net capacity (L)	170	380	380	380
Cooling system	Static	Ventilated	Static with fan cooling	Ventilated
Temperature (°C)	0~+8	-18~-22	0~+8	0~+8
Shelves No.	1+1	6+1	3+1	3+1
Interior light	Yes	Yes	Yes	Yes
Compressor	ZEL/ZEL	Embraco/ZEL	ZEL/ZEL	ZEL/ZEL
Digital thermostat	Dixell	Dixell/Elitech	Dixell	Dixell
Kind of coolant	R134a/R600a	R404a/R290	R134a/R600a	R134a/R600a
40' Container loading	108	54	54	54

UPRIGHT CHILLER/FREEZER



SR-60VG

**Features**

- European standard glass door upright chiller
- Digital Thermostat
- Lock and key
- Fan assisted cooling system
- Reversible self-closing door
- Roll bond plate with fan
- Two front adjustable feet, two rear wheels

Options

- Outside door stainless steel material or white pre-painted steel
- Eliwell / Dixell

Product Model	SF-60VG	SR-60G	SR-60VG
Unit dimensions (W/D/H mm)	775*723*1840	775*723*1840	775*723*1840
Net capacity (L)	590	590	590
Cooling system	Ventilated	Static with fan cooling	Ventilated
Temperature (°C)	-18~-22	0~+8	0~+8
Shelves No.	6+1	3+1	3+1
Interior light	Yes	Yes	Yes
Compressor	Embraco/ZEL	ZEL/ZEL	ZEL/ZEL
Digital thermostat	Dixell/Elitech	Dixell	Dixell
Kind of coolant	R404a/R290	R134a/R600a	R134a/R600a
40' Container loading	42	42	42



SUPERMARKET &
CONVENIENT
STORE
REFRIGERATION

MINI PROMOTIONAL BEVERAGE CABINET



BLF-706

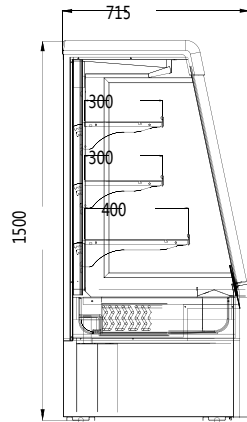

Features

- Digital controller
- Finned evaporator
- Automatic defrost
- LED light for every shelf
- With night curtain
- Adjustable shelves
- With price label setting
- Automatic drain water

Options

- Various color for the part
- LED light or ordinary light
- Side wall material

Product Model	BLF-706
Unit dimensions (W/D/H mm)	750*740*1500
Packing dimensions (W/D/H mm)	780*845*1660
Effective Volume (M ³)	0.16
Display area (M ²)	0.52
Kind of coolant	R404a/R290
Temperature (°C)	3M2
Compressor	Embraco/Secop
Digital thermostat	Dixell
Light	LED light
40' HC Container load	45

MINI PROMOTIONAL BEVERAGE CABINET



Features

- Digital controller
- Finned evaporator
- Automatic defrost
- LED light for every shelf
- With night curtain
- Adjustable shelves
- With price label setting
- Automatic drain water

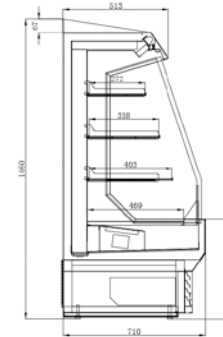

BLF-706A

Product Model	BLF-706A
Unit dimensions (W/D/H mm)	660*700*1460
Packing dimensions (W/D/H mm)	740*760*1600
Effective Volume (M ³)	0.165
Display area (M ²)	1.4
Kind of coolant	R404a/R290
Temperature (°C)	3M2
Compressor	Embraco/Secop
Digital thermostat	Dixell
Light	LED light
40' HC Container load	45

MINI PROMOTIONAL BEVERAGE CABINET



Features

- Digital controller
- Finned evaporator
- Automatic defrost
- LED light for every shelf
- With night curtain
- Adjustable shelves
- With price label setting
- Automatic drain water



BLF-706B

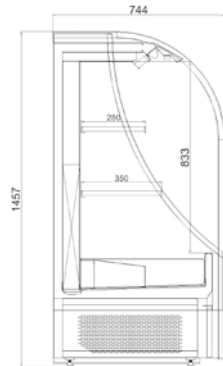

Product Model	BLF-706B
Unit dimensions (W/D/H mm)	660*700*1460
Packing dimensions (W/D/H mm)	780*800*1660
Effective Volume (M ³)	0.165
Display area (M ²)	1.4
Kind of coolant	R404a/R290
Temperature (°C)	3M2
Compressor	Embraco/Secop
Digital thermostat	Dixell
Light	LED light
40' HC Container load	42

MINI PROMOTIONAL BEVERAGE CABINET

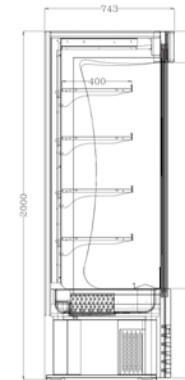

Features

- Triple pan evaporation system
- Cassette system for easy maintenance and service
- Night blind to reduce energy consumption
- At-front product presentation without door
- Energy efficient
- Energy saving management
- Automatic defrost and condensate evaporation
- Four adjustable shelves plus bottom shelf
- Shelf supports can be fixed in inclined position
- Space keeper in the back
- 4 wheels
- Two side LED light+Top LED light
- All options on demand



BLF-926

Product Model	BLF-926
Unit dimensions (W/D/H mm)	896*717*2040
Packing dimensions (W/D/H mm)	1010*850*2120
Effective Volume (M ³)	0.42
Display area (M ²)	1.24
Kind of coolant	R404A
Temperature (°C)	3M2
Compressor	Embraco
Digital thermostat	Dixell
Light	LED light
40' HC Container load	28

PROME COOLER



BLF-406P (Carton Cabinet)



Features

- The Promo Cooler is a compact cardboard chiller .
- Yet performance is comparable to conventional units.
- Interchangeable sleeves are made from disposable biodegradable cardboard.
- Sleeves are easy to swap, so you can tie your promo cooler in to seasonal short run promotions, special offers or local trends, etc.
- LED lighting

Product Model	BLF-406G	BLF-406P
Unit dimensions (W/D/H mm)	450*450*1475	450*450*1475
Packing dimensions (W/D/H mm)	540*540*695	540*540*695
Cooling system	No Frost	No Frost
Net capacity	90	45
Display Area (M ²)	0.12	0.14
Kind of coolant	R134a/R290	R134a/R290
Temperature range (°C)	+2~+10	+2~+10
Compressor	Embraco/Secop	Embraco/Secop
Thermostat	Dixell	Dixell
40' Container load	264	264

PROMOTION CABINET



STP-1310



STP-1310G

Features

- Ventilated cooling
- Danfoss expansion Valve(R404a)
- Hot gas pipe for auto condensate water
- Copper-aluminium fin evaporator+Fan
- Automatic defrosting
- 4 Adjustable feet
- More display area

Options

- Glass door
- Sliding

Product Model	STP-1310	STP-1310G
Unit dimensions (W/D/H mm)	1370*1080*935mm	1370*1080*900mm
Packing dimensions (W/D/H mm)	1450*1150*1100mm	1450*1150*1100mm
Cooling system	No Frost	No Frost
Net capacity	190	190
Display Area (M ²)	2.12	2.12
Kind of coolant	R404a/R290	R404a/R290
Temperature range (°C)	3M2	3M1
Compressor	Embraco/Secop	Embraco/Secop
Thermostat	Dixell	Dixell
40' Container load	32(2 Layer)	32(2 Layer)

MULTIDECK-PLUG IN 660MM DEPTH WITH NIGHT CURTAIN



BLF-2066

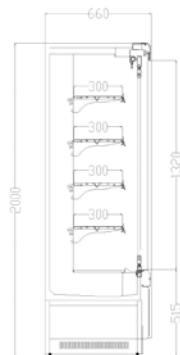

Features

- Inner temperature: M1/M2
- Digital controller
- Finned evaporator
- Thermostatic expansion valve
- Automatic defrost
- LED light for every shelf
- With night curtain
- Without door
- Adjustable shelves
- With price label setting
- Automatic drain water
- R404A
- Side double tempered glass

Options

- Various color for the part
- Thickness and material of the steel
- LED light or ordinary light
- with plexiglass door
- Side wall material

Product Model	BLF-1066	BLF-1366	BLF-1566	BLF-2066
Unit Dimension (W/D/H mm)	1000*660*2000	1430*660*2000	1500*660*2000	1940*660*2000
Packing Dimension (W/D/H mm)	1120*780*2155	1450*780*2155	1640*780*2155	2080*780*2155
Effective Volume (M ³)	0.36	0.47	0.54	0.72
Display Area (M ²)	1.24	1.65	1.9	2.48
Cooling System	Ventilated Cooling	Ventilated Cooling	Ventilated Cooling	Ventilated Cooling
Light	LED Light	LED Light	LED Light	LED Light
Temperature (°C)	3M2	3M2	3M2	3M2
Compressor	Embraco	Embraco	Embraco	Embraco
Kind of Coolant	R404a	R404a	R404a	R404a
40 GP Container Loading (Pcs)	30	24	21	16

MULTIDECK-PLUG IN 787MM DEPTH NIGHT CURTAIN



BLF-1280

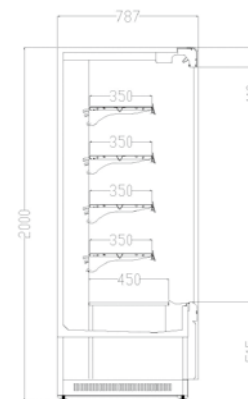

Features

- Inner temperature: M1/M2
- Digital controller
- Finned evaporator
- Thermostatic expansion valve
- Automatic defrost
- LED light for every shelf
- With night curtain
- Without door
- Adjustable shelves
- With price label setting
- Automatic drain water
- R404A
- Side double tempered glass

Options

- Various color for the part
- Thickness and material of the steel
- LED light or ordinary light
- with plexiglass door
- Side wall material



Product Model	BLF-1080	BLF-1380	BLF-1580	BLF-2080
Unit Dimension (W/D/H mm)	997*787*2000	1310*787*2000	1500*787*2000	1935*787*2000
Packing Dimension (W/D/H mm)	1120*900*2150	1430*900*2155	1620*960*2155	2075*920*2155
Effective Volume (M ³)	0.42	0.55	0.63	0.84
Display Area (M ²)	1.24	1.65	1.9	2.48
Cooling System	Ventilated Cooling	Ventilated Cooling	Ventilated Cooling	Ventilated Cooling
Light	LED Light	LED Light	LED Light	LED Light
Temperature (°C)	3M2	3M2	3M2	3M2
Compressor	Embraco	Embraco	Embraco	Embraco
Kind of Coolant	R404a	R404a	R404a	R404a
40 GP Container Loading (Pcs)	26	21	14	13

MULTIDECK-PLUG IN 690MM DEPTH NIGHT CURTAIN

Features

- Inner temperature: M1/M2
- Digital controller
- Finned evaporator
- Thermostatic expansion valve
- Automatic defrost
- LED light for every shelf
- With night curtain
- Without door
- Adjustable shelves
- With price lable setting
- Automatic drain water
- R404A
- Side double tempered glass
- Various color for the part
- Thickness and material of the steel
- LED light or ordinary light
- with plexiglass door
- Side wall material

Options

- Various color or the part
- Thickness and material of the steel
- LED light or ordinary light
- with plexiglass door
- Side wall material

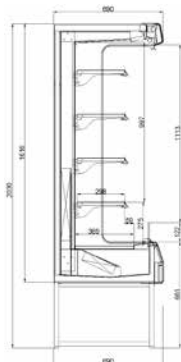

BLF-1369

Product Model	BLF-1069	BLF-1369	BLF-1569
Unit Dimension (W/D/H mm)	997*690*2030	1310*690*2030	1560*90*2030
Packing Dimension (W/D/H mm)	1119*790*2220	1432*790*2220	1682*790*2220
Display Area	1.2	1.6	1.92
Effective Volume	0.384	0.512	0.615
Cooling System	Ventilated	Ventilated	Ventilated
Temperature range	3M2	3M2	3M2
Kind of Refrigerant	R404A	R404A	R404A
Compressor	embraco	embraco	embraco
Evaporator Fan Brand	EBM	EBM	EBM
Controller Brand	DIXELL	DIXELL	DIXELL
Light	LED LIGHT	LED LIGHT	LED LIGHT
40 Container Loading (Pcs)	30	23	15

MULTIDECK-PLUG IN 865MM DEPTH WITH NIGHT CURTAIN

Features

- Inner temperature: M1/M2
- Digital controller
- Finned evaporator
- Thermostatic expansion valve
- Automatic defrost
- LED light for every shelf
- With night curtain
- Without door
- Adjustable shelves
- With price lable setting
- Automatic drain water
- R404A
- Side double tempered glass
- Various color for the part
- Thickness and material of the steel
- LED light or ordinary light
- with plexiglass door
- Side wall material

Options

- Various color for the part
- Thickness and material of the steel
- LED light or ordinary light
- with plexiglass door
- Side wall material



BLF-2087

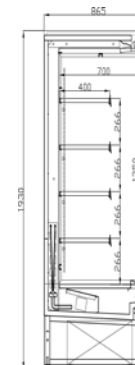

Product Model	BLF-1087	BLF-1387	BLF-1587	BLF-2087
Unit Dimension (W/D/H mm)	1000*865*1930	1310*865*1930	1500*865*1930	1940*865*1930
Packing Dimension (W/D/H mm)	1150*1050*2130	1450*1050*2130	1650*1050*2130	2070*1050*2130
Display Area	1.25	1.65	2.13	2.78
Effective Volume	0.59	0.83	0.86	1.12
Cooling System	Ventilated	Ventilated	Ventilated	Ventilated
Temperature range	3M2	3M2	3M2	3M2
Kind of Refrigerant	R404A	R404A	R404A	R404A
Compressor	embraco	CRSS(SANYO)	CRSS(SANYO)	CRSS(SANYO)
Evaporator Fan Brand	EBM	EBM	EBM	EBM
Controller Brand	DIXELL	DIXELL	DIXELL	DIXELL
Light	LED LIGHT	LED LIGHT	LED LIGHT	LED LIGHT
40 Container Loading (Pcs)	22	16	14	11

QINGDAO SANTA INTERNATIONAL CO.,LTD

MULTIDECK-PLUG IN 660MM DEPTH WITH SINGLE TEMPERED GLASS DOOR



BLF-1566GA

BLF-1066GA

Features

- Inner temperature: M1
- Digital controller
- Finned evaporator
- Thermostatic expansion valve
- Automatic defrost
- LED light for every shelf
- With tempered door
- Adjustable shelves
- With price label setting
- Automatic drain water
- R404A

Options

- Various color for the part
- Thickness and material of the steel
- LED light or ordinary light
- Side wall material
- Only available for outside Europe



Product Model	BLF-1066GA	BLF-1366GA	BLF-1566GA	BLF-2066GA
Unit Dimension (W/D/H mm)	1000*660*2000	1430*660*2000	1500*660*2000	1940*660*2000
Packing Dimension (W/D/H mm)	1120*780*2155	1450*780*2155	1640*780*2155	2080*780*2155
Effective Volume (M ³)	0.36	0.47	0.54	0.72
Display Area (M ²)	1.24	1.65	1.9	2.48
Cooling System	Ventilated Cooling	Ventilated Cooling	Ventilated Cooling	Ventilated Cooling
Light	LED Light	LED Light	LED Light	LED Light
Temperature (°C)	3M1	3M1	3M1	3M1
Compressor	Embraco	Embraco	Embraco	Embraco
Kind of Coolant	R404a	R404a	R404a	R404a
40 GP Container Loading (Pcs)	30	24	21	16

www.santagroup.com.cn info@santagroup.com.cn

QINGDAO SANTA INTERNATIONAL CO.,LTD

MULTIDECK-PLUG IN 787MM DEPTH WITH SINGLE TEMPERED GLASS DOOR



BLF-2080GA

BLF-1080GA

Features

- Inner temperature: M1
- Digital controller
- Finned evaporator
- Thermostatic expansion valve
- Automatic defrost
- LED light for every shelf
- With tempered door
- Adjustable shelves
- With price label setting
- Automatic drain water
- R404A

Options

- Various color for the part
- Thickness and material of the steel
- LED light or ordinary light
- Side wall material
- Only available for outside Europe



Product Model	BLF-1080GA	BLF-1380GA	BLF-1580GA	BLF-2080GA
Unit Dimension (W/D/H mm)	997*787*2000	1310*787*2000	1500*787*2000	1935*787*2000
Packing Dimension (W/D/H mm)	1120*900*2150	1430*900*2155	1620*960*2155	2075*920*2155
Effective Volume (M ³)	0.42	0.55	0.63	0.84
Display Area (M ²)	1.24	1.65	1.9	2.48
Cooling System	Ventilated Cooling	Ventilated Cooling	Ventilated Cooling	Ventilated Cooling
Light	LED Light	LED Light	LED Light	LED Light
Temperature (°C)	3M1	3M1	3M1	3M1
Compressor	Embraco	Embraco	Embraco	Embraco
Kind of Coolant	R404a	R404a	R404a	R404a
40 GP Container Loading (Pcs)	26	21	14	13

www.santagroup.com.cn info@santagroup.com.cn

MULTIDECK-PLUG IN 660MM DEPTH WITH DOUBLE GLASS DOOR AND NONE FRAME



Features

- Inner temperature: M1/M2
- Digital controller
- Finned evaporator
- Thermostatic expansion valve
- Automatic defrost
- LED light for every shelf
- With door
- Adjustable shelves
- With price lable setting
- Automatic drain water
- R404A
- Side double tempered glass

Options

- Various color for the part
- Thickness and material of the steel
- LED light or ordinary light
- Side wall material

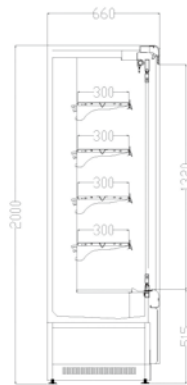

BLF-2066GB



Product Model	BLF-1366GB	BLF-2066GB	BLF-2566GB
Unit Dimension (W/D/H mm)	1310*660*2000	1940*660*2000	2560*660*2000
Packing Dimension (W/D/H mm)	1450*780*2155	2080*780*2155	2700*780*2155
Effective Volume (M ³)	0.53	0.82	0.98
Display Area (M ²)	1.66	2.48	3.31
Cooling System	Ventilated Cooling	Ventilated Cooling	Ventilated Cooling
Light	LED Light	LED Light	LED Light
Glass Door No.	2	3	4
Temperature (°C)	3M1	3M1	3M1
Compressor	Embraco	Embraco	Embraco
Kind of Coolant	R404a	R404a	R404a
40 GP Container Loading (Pcs)	24	16	12

MULTIDECK-PLUG IN 787MM DEPTH WITH DOUBLE GLASS DOOR AND NONE FRAME



Features

- Inner temperature: M1/M2
- Digital controller
- Finned evaporator
- Thermostatic expansion valve
- Automatic defrost
- LED light for every shelf
- With door
- Adjustable shelves
- With price lable setting
- Automatic drain water
- R404A

Options

- Various color for the part
- Thickness and material of the steel
- LED light or ordinary light
- Side wall material

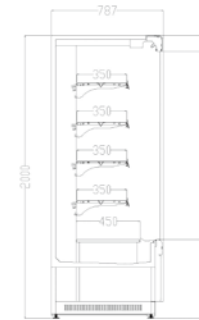

BLF-1080GB



Product Model	BLF-1380GB	BLF-2080GB	BLF-2580GB
Unit Dimension (W/D/H mm)	1310*787*2000	1935*787*2000	2000*920*2155
Packing Dimension (W/D/H mm)	1450*920*2155	2075*920*2155	2560*787*2000
Effective Volume (M ³)	0.62	0.95	1.14
Display Area (M ²)	1.66	2.48	3.31
Cooling System	Ventilated Cooling	Ventilated Cooling	Ventilated Cooling
Light	LED Light	LED Light	LED Light
Glass Door No.	2	3	4
Temperature (°C)	3M1	3M1	3M1
Compressor	Embraco	Embraco	Embraco
Kind of Coolant	R404a	R404a	R404a
40 GP Container Loading (Pcs)	16	13	9

MULTIDECK-PLUG IN 660MM DEPTH WITH DOUBLE VACUUM GLASS DOOR AND ALLOY FRAME



BLF-2566GC

Features

- Inner temperature: M1/M2
- Digital controller
- Finned evaporator
- Thermostatic expansion valve
- Automatic defrost
- LED light
- Adjustable shelves
- With price label setting
- Automatic drain water
- R404A

Options

- Various color for the part
- Thickness and material of the steel
- LED light or ordinary light
- Side wall material

Product Model	BLF-1366GC	BLF-2066GC	BLF-2566GC
Unit Dimension (W/D/H mm)	1310*660*2000	1940*660*2000	2560*660*2000
Packing Dimension (W/D/H mm)	1450*780*2155	2080*780*2155	2700*780*2155
Effective Volume (M ³)	0.53	0.82	0.98
Display Area (M ²)	1.66	2.48	3.31
Cooling System	Ventilated Cooling	Ventilated Cooling	Ventilated Cooling
Light	LED Light	LED Light	LED Light
Glass Door No.	2	3	4
Temperature (°C)	3M1	3M1	3M1
Compressor	Embraco	Embraco	Embraco
Kind of Coolant	R404a	R404a	R404a
40 GP Container Loading (Pcs)	24	16	12

MULTIDECK-PLUG IN 787MM DEPTH WITH DOUBLE GLASS DOOR AND ALLOY FRAME



Features

- Inner temperature: M1/M2
- Digital controller
- Finned evaporator
- Thermostatic expansion valve
- Automatic defrost
- LED light
- With night curtain
- Without plexiglass door
- Adjustable shelves
- With price label setting
- Automatic drain water
- R404A

Options

- Various color for the part
- Thickness and material of the steel
- LED light or ordinary light
- Side wall material

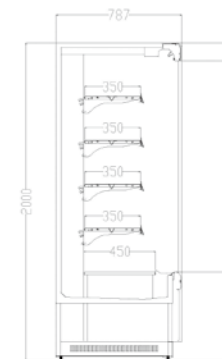

BLF-1380GC

Product Model	BLF-1380GC	BLF-2080GC	BLF-2580GC
Unit Dimension (W/D/H mm)	1310*787*2000	1935*787*2000	2560*787*2000
Packing Dimension (W/D/H mm)	1450*920*2155	2075*920*2155	2000*920*2155
Effective Volume (M ³)	0.62	0.95	1.14
Display Area (M ²)	1.66	2.48	3.31
Cooling System	Ventilated Cooling	Ventilated Cooling	Ventilated Cooling
Light	LED Light	LED Light	LED Light
Glass Door No.	2	3	4
Temperature (°C)	3M1	3M1	3M1
Compressor	Embraco	Embraco	Embraco
Kind of Coolant	R404a	R404a	R404a
40 GP Container Loading (Pcs)	16	13	9

MULTIDECK-PLUG IN COOLER WITH DOUBLE GLASS DOOR&FREEZER WITH TRIPLE GLASS DOOR

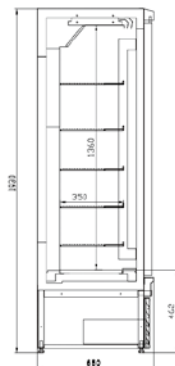

Features

- Inner temperature: M1/M2
- Digital controller
- Finned evaporator
- Thermostatic expansion valve
- Automatic defrost
- LED light
- Adjustable shelves
- With price label setting
- Automatic drain water
- R404A



Product Model	BLG-1265C	BLG-1265F	BLG-1865C	BLG-1865F
Unit Dimension (W/D/H mm)	1220*650*1930	1220*650*1930	1830*650*1930	1830*650*1930
Packing Dimension (W/D/H mm)	1400*780*2100	1400*780*2100	1980*780*2100	1980*780*2100
Effective Volume(M ³)	0.76	0.76	1.17	1.17
Display Area (M ²)	1.75	1.75	2.62	2.62
Cooling System	Ventilated Cooling	Ventilated Cooling	Ventilated Cooling	Ventilated Cooling
Light	LED	LED	LED	LED
Glass Door No.	2	2	3	3
Temperature (°C)	3M1/3E2	3L1	3M1/3E2	3L1
Compressor	SECOP	CRSS	SECOP	CRSS
Kind of Coolant	R404A/R290	R404A/R290	R404A/R290	R404A/R290
40 GP Container Loading (Pcs)	24	24	18	18

MULTIDECK-REMOTE COOLER WITH DOUBLE GLASS DOOR

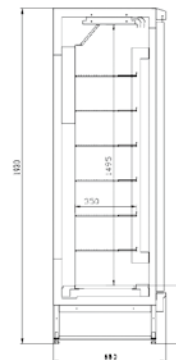

Features

- Inner temperature: M1/M2
- Digital controller
- Finned evaporator
- Thermostatic expansion valve
- Automatic defrost
- LED light
- Adjustable shelves
- With price label setting
- Automatic drain water
- R404A



Product Model	BLG-1265C	BLG-1865C
Unit Dimension (W/D/H mm)	1220*650*1930	1830*650*1930
Packing Dimension (W/D/H mm)	1980*790*2100	1980*790*2100
Effective Volume(M ³)	0.83	1.28
Display Area (M ²)	1.92	2.88
Cooling System	Ventilated Cooling	Ventilated Cooling
Light	LED	LED
Glass Door No.	2	3
Temperature (°C)	3M1/3E2	3M1/3E2
Kind of Coolant	R404A	R404A
40 GP Container Loading (Pcs)	24	18

MULTIDECK-REMOTE 675&735MM DEPTH WITH NIGHT CURTAIN

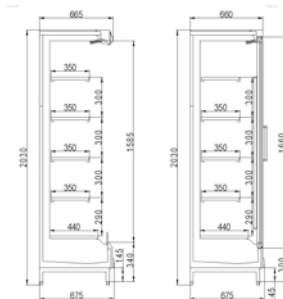

Features

- R404a refrigerant.
- Low energy consumption and high cooling capacity.They are achieved by increasing evaporation temperature and heat exchange amount of efficient evaporator.
- Designedly a solenoid valve in each cabinet,in front of which a filter is installed with the purpose of guarding against blockage,reducing difficulty and time of installation.
- Huge open space,low front edge,all maximize display effect.
- More volume is achieved by maximizing shelf depth in a certain freezer width.
- To make the most of the depth of display rack,this gives a larger effective volume.
- LED top lamp,with shelves LED light and non-lamp for optional.
- Super wide night curtain minimizes the gaps between curtains to save more energy.
- Top tubing design makes construction easier.
- Off-cycle defrost reduces energy consumption.
- Glass gable and solid gable for optional.



Product Model	CLF-1368	CLF-1374	CLF-2068	CLF-2074	CLF-2568	CLF-2574
Unit Dimension (W/D/H mm)	1310*675*1930	1310*735*1930	1935*675*1930	1935*735*1930	2560*675*1930	2560*735*1930
Packing dimensions (W / D/ H mm)	1484*775*2090	1484*845*2090	2109*775*2090	2109*845*2090	2734*775*2090	2734*845*2090
Display Area(M2)	1.97	1.97	2.96	2.96	3.94	3.94
Effective Volume	0.69	0.71	1.03	1.06	1.46	1.5
Cooling system	Ventilated	Ventilated	Ventilated	Ventilated	Ventilated	Ventilated
Temperature range	3M2	3M2	3M2	3M2	3M2	3M2
Kind of Refrigerant	R404A	R404A	R404A	R404A	R404A	R404A
Cooling Capacity	1550	1755	2325	2600	3100	3470
Evaporator Fans brand	EBM	EBM	EBM	EBM	EBM	EBM
Controller Brand	CAREL	CAREL	CAREL	CAREL	CAREL	CAREL
Light	LED LIGHT	LED LIGHT	LED LIGHT	LED LIGHT	LED LIGHT	LED LIGHT
40° Container load	24	22	16	14	8	8

MULTIDECK-REMOTE 675&785MM DEPTH WITH DOUBLE GLASS DOOR

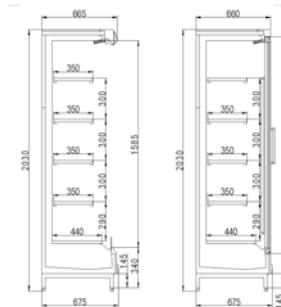

Features

- R404a refrigerant.
- Low energy consumption and high cooling capacity.They are achieved by increasing evaporation temperature and heat exchange amount of efficient evaporator.
- Designedly a solenoid valve in each cabinet,in front of which a filter is installed with the purpose of guarding against blockage,reducing difficulty and time of installation.
- Huge open space,low front edge,all maximize display effect.
- More volume is achieved by maximizing shelf depth in a certain freezer width.
- To make the most of the depth of display rack,this gives a larger effective volume.
- LED top lamp,with shelves LED light and non-lamp for optional.
- Super wide night curtain minimizes the gaps between curtains to save more energy.
- Top tubing design makes construction easier.
- Off-cycle defrost reduces energy consumption.
- Glass gable and solid gable for optional.



Product Model	CLF-1368G	CLF-1374G	CLF-2068G	CLF-2074G	CLF-2568G	CLF-2574G
Unit Dimension (W/D/H mm)	1310*735*1930	1310*735*1930	1935*735*1930	1935*735*1930	2560*735*1930	2560*735*1930
Packing dimensions (W / D/ H mm)	1484*775*2090	1484*845*2090	2109*775*2090	2109*845*2090	2734*775*2090	2734*845*2090
Display Area(M2)	1.35	1.35	2.03	2.03	2.71	2.71
Effective Volume (L)	0.69	0.71	1.03	1.06	1.46	1.5
Cooling system	Ventilated	Ventilated	Ventilated	Ventilated	Ventilated	Ventilated
Temperature range	3M1	3M1	3M1	3M1	3M1	3M1
Kind of Refrigerant	R404A	R404A	R404A	R404A	R404A	R404A
Cooling Capacity	775	867	1165	1303	1550	1734
Evaporator Fans brand	EBM	EBM	EBM	EBM	EBM	EBM
Controller Brand	CAREL	CAREL	CAREL	CAREL	CAREL	CAREL
Light	LED LIGHT	LED LIGHT	LED LIGHT	LED LIGHT	LED LIGHT	LED LIGHT
40° Container load	22	22	14	14	8	8

MULTIDECK-REMOTE 870MM DEPTH WITH NIGHT CURTAIN

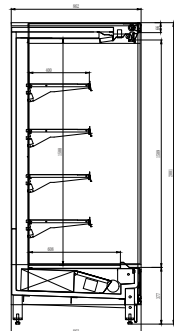

Features

- R404a/R744 refrigerant
- For the purpose of high efficiency and low energy consumption, increase the heat transfer, we use efficient evaporator to increase the evaporation temperature and exchange amount.
- There is a solenoid valve for each cabinet. We put a filter in front of the solenoid valve to reduce the difficulty and period of installation, limit the risk of dirt blockage.
- Low front edge with huge open space maximizes the food display effect.
- Maximize the shelf depth with in a limited freezer width to provide more effective volume
- Optional high efficiency fan and LED lamps can be selected according to customers' requirement
- Top tubing design makes construction easier
- Ultra wide high quality night curtain minimizes the gaps between curtains to save more energy.
- Off-cycle defrost reduces the energy consumption.



Product Model	CLF-1387	CLF-2087	CLF-2587	CLF-3787
Unit Dimension (W/D/H mm)	1250*870*2000	1875*870*2000	2500*870*2000	3750*870*2000
Packing dimensions (W / D/ H mm)	1500*960*2250	2100*960*2250	2700*960*2250	3950*960*2250
Display Area(M ²)	3.03	4.29	6.08	8.65
Effective Volume	1.12	1.42	1.79	2.65
Cooling system	Ventilated	Ventilated	Ventilated	Ventilated
Temperature range	3M2	3M2	3M2	3M2
Kind of Refrigerant	R404A	R404A	R404A	R404A
Cooling Capacity	1500	2200	2900	4200
Evaporator Fans brand	EBM	EBM	EBM	EBM
Controller Brand	DIXELL	DIXELL	DIXELL	DIXELL
Light	LED LIGHT	LED LIGHT	LED LIGHT	LED LIGHT
40' Container load	15	12	8	6

MULTIDECK-REMOTE 870MM DEPTH WITH DOUBLE GLASS DOOR

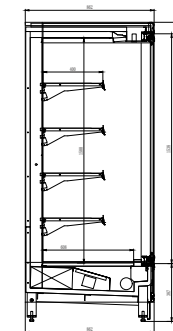

Features

- R404a/R744 refrigerant
- For the purpose of high efficiency and low energy consumption, increase the heat transfer, we use efficient evaporator to increase the evaporation temperature and exchange amount.
- There is a solenoid valve for each cabinet. We put a filter in front of the solenoid valve to reduce the difficulty and period of installation, limit the risk of dirt blockage.
- Low front edge with huge open space maximizes the food display effect.
- Maximize the shelf depth with in a limited freezer width to provide more effective volume
- Optional high efficiency fan and LED lamps can be selected according to customers' requirement
- Top tubing design makes construction easier
- Ultra wide high quality night curtain minimizes the gaps between curtains to save more energy.
- Off-cycle defrost reduces the energy consumption.



Product Model	CLF-1387G	CLF-2087G	CLF-2587G	CLF-3787G
Unit Dimension (W/D/H mm)	1250*870*2000	1875*870*2000	2500*870*2000	3750*870*2000
Packing dimensions (W / D/ H mm)	1500*960*2250	2100*960*2250	2700*960*2250	3950*960*2250
Display Area(M ²)	3.03□	4.29□	6.08□	8.65□
Effective Volume	1.12	1.42	1.79	2.65
Cooling system	Ventilated	Ventilated	Ventilated	Ventilated
Temperature range	3M2	3M2	3M2	3M2
Kind of Refrigerant	R404A	R404A	R404A	R404A
Cooling Capacity	1200	1700	2100	3400
Evaporator Fans brand	EBM	EBM	EBM	EBM
Controller Brand	DIXELL	DIXELL	DIXELL	DIXELL
Light	LED LIGHT	LED LIGHT	LED LIGHT	LED LIGHT
40' Container load	15	12	8	6

MULTIDECK-REMOTE 918MM DEPTH WITH NIGHT CURTAIN



Features

- R404a/R744 refrigerant
- For the purpose of high efficiency and low energy consumption, increase the heat transfer, we use efficient evaporator to increase the evaporation temperature and exchange amount.
- There is a solenoid valve for each cabinet. We put a filter in front of the solenoid valve to reduce the difficulty and period of installation, limit the risk of dirt blockage.
- Low front edge with huge open space maximizes the food display effect.
- Maximize the shelf depth with in a limited freezer width to provide more effective volume
- Optional high efficiency fan and LED lamps can be selected according to customers' requirement
- Top tubing design makes construction easier
- Ultra wide high quality night curtain minimizes the gaps between curtains to save more energy.
- Off-cycle defrost reduces the energy consumption.

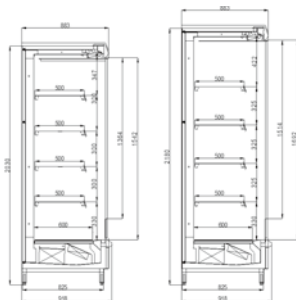

Product Model	CLF-2092	CLF-2092H	CLF-2592	CLF-2592H	CLF-3892	CLF-3892H
Unit Dimension (W/D/H mm)	1935*918*2030	1935*918*2180	2560*918*2030	2560*918*2180	3810*918*2030	3810*918*2180
Packing dimensions (W / D / H mm)	2120*1100*2200	2120*1100*2200	2820*1100*2200	2820*1100*2200	4170*1100*2200	4170*1100*2200
Display Area(M ²)	2.94	3.22	3.92	4.29	5.88	6.44
Effective Volume (L)	1.6	1.74	2.14	2.33	3.21	3.49
Cooling system	Ventilated	Ventilated	Ventilated	Ventilated	Ventilated	Ventilated
Temperature range	3M1	3M1	3M1	3M1	3M1	3M1
Kind of Refrigerant	R404A	R404A	R404A	R404A	R404A	R404A
Cooling Capacity	3070	3530	3900	4480	5840	6720
Evaporator Fans brand	EBM	EBM	EBM	EBM	EBM	EBM
Controller Brand	CAREL	CAREL	CAREL	CAREL	CAREL	CAREL
Light	LED LIGHT	LED LIGHT	LED LIGHT	LED LIGHT	LED LIGHT	LED LIGHT
40' Container load	11	11	8	8	4	4

MULTIDECK-REMOTE 918MM DEPTH WITH DOUBLE GALSS DOOR



Features

- R404a/R744 refrigerant
- For the purpose of high efficiency and low energy consumption, increase the heat transfer, we use efficient evaporator to increase the evaporation temperature and exchange amount.
- There is a solenoid valve for each cabinet. We put a filter in front of the solenoid valve to reduce the difficulty and period of installation, limit the risk of dirt blockage.
- Low front edge with huge open space maximizes the food display effect.
- Maximize the shelf depth with in a limited freezer width to provide more effective volume
- Optional high efficiency fan and LED lamps can be selected according to customers' requirement
- Top tubing design makes construction easier
- Ultra wide high quality night curtain minimizes the gaps between curtains to save more energy.
- Off-cycle defrost reduces the energy consumption.

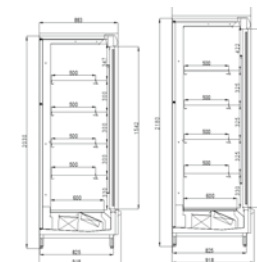

Product Model	CLF-2092G	CLF-2092HG	CLF-2592G	CLF-2592HG	CLF-3892G	CLF-3892HG
Unit Dimension (W/D/H mm)	1935*918*2030	1935*918*2180	2560*918*2030	2560*918*2180	3810*918*2030	3810*918*2180
Packing dimensions (W / D / H mm)	2120*1100*2200	2120*1100*2350	2820*1100*2200	2820*1100*2350	4170*1100*2200	4170*1100*2350
Display Area(M ²)	2.10	2.38	2.80	3.18	4.20	4.76
Effective Volume (L)	1.6	1.74	2.14	2.33	3.21	3.49
Cooling system	Ventilated	Ventilated	Ventilated	Ventilated	Ventilated	Ventilated
Temperature range	3M1	3M1	3M1	3M1	3M1	3M1
Kind of Refrigerant	R404A	R404A	R404A	R404A	R404A	R404A
Cooling Capacity	1500	1765	1950	2240	2920	3360
Evaporator Fans brand	EBM	EBM	EBM	EBM	EBM	EBM
Controller Brand	CAREL	CAREL	CAREL	CAREL	CAREL	CAREL
Light	LED LIGHT	LED LIGHT	LED LIGHT	LED LIGHT	LED LIGHT	LED LIGHT
40' Container load	11	11	8	8	4	4

MULTIDECK-REMOTE 1060MM DEPTH WITH NIGHT CURTAIN

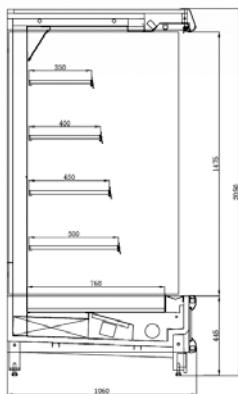

Features

- Inner temperature: M1/M2
- Digital controller
- Finned evaporator
- Thermostatic expansion valve
- Automatic defrost
- LED light for every shelf
- With night curtain
- With plexiglass door
- Adjustable shelves
- With price label setting
- Automatic drain water
- R404A
- Side double tempered glass

Product Model	CLF-19110	CLF-25110	CLF-38110
Unit dimensions (W/D/H mm)	1875x1060x2050	2500x1060x2050	3750x1060x2050
Packing dimensions (W/D/H mm)	2175x1220x2250	2780x1220x2250	3950x1220x2250
Display Area(m ²)	5.05	7.15	10.18
Effective Volume (m ³)	1.67	2.11	3.12
Cooling system	Ventilated	Ventilated	Ventilated
Temperature range	3M1	3M1	3M1
Kind of Refrigerant	R404A	R404A	R404A
Cooling Capacity	2800	3200	4700
Evaporator Fans brand	EBM	EBM	EBM
Controller Brand	CAREL	CAREL	CAREL
Light	LED LIGHT	LED LIGHT	LED LIGHT
40' Container load	9	4	3

MULTIDECK-REMOTE 1060MM DEPTH WITH DOUBLE GLASS DOOR

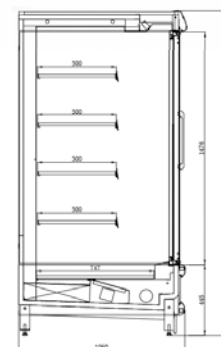

Features

- Suitable for dairy products, meat, fruits and vegetables and drink
- Efficient anti-fog glass door
- LED lighting, energy saving province electricity
- Danfoss valves, EBM fan
- Around the revolving door/sliding door is optional

Product Model	CLF-19110G	CLF-25110G	CLF-38110G
Unit dimensions (W/D/H mm)	1875x1060x2050	2500x1060x2050	3750x1060x2050
Packing dimensions (W/D/H mm)	2175x1220x2250	2780x1220x2250	3950x1220x2250
Display Area(m ²)	5.05	7.15	10.18
Effective Volume (m ³)	1.67	2.11	3.12
Cooling system	Ventilated	Ventilated	Ventilated
Temperature range	3M1	3M1	3M1
Kind of Refrigerant	R404A	R404A	R404A
Cooling Capacity	2200	2500	3900
Evaporator Fans brand	EBM	EBM	EBM
Controller Brand	CAREL	CAREL	CAREL
Light	LED LIGHT	LED LIGHT	LED LIGHT
40' Container load	9	4	3

MULTIDECK-REMOTE 918MM DEPTH FREEZER WITH NIGHT CURTAIN



Features

- R404a/R744 refrigerant.
- To reduce energy consumption, increase cooling capability, we use efficient evaporator, increase the evaporation temperature to -30 degrees.
- There is a solenoid valve for each cabinet. We put a filter in front of the solenoid valve to reduce the difficulty and period of installation, limit the risk of dirt blockage.
- Low front edge with huge open space maximizes the food display effect.
- The glass door frame uses integrated structure, easy for assembling. It has high intensity and luxury appearance.
- According to customer's requirement, anti-mist film can be used to provide a better display effect.
- Optional high efficiency fan and LED lamps can be selected according to customer's requirement.
- Top tubing design makes construction easier.
- Plastic divider is a standard figure. It separates the space between each door, effectively prevents cold air leak, making it more energy saving.

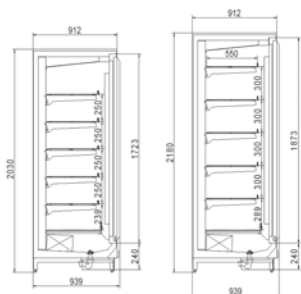

Product Model	CLG-2392F	CLG-2392FH	CLG-3092F	CLG-3092FH	CLG-3892F	CLG-3892FH
Unit Dimension (W/D/H mm)	2350*918*2030	2350*918*2180	3100*918*2030	3100*918*2180	3850*918*2030	3850*918*2180
Packing Dimensions (W / D / H mm)	2500*1035*2177	2500*1035*2327	3250*1035*2177	3250*1035*2327	4000*1035*2177	4000*1035*2327
Display Area(M ²)	2.57	2.81	3.42	3.74	4.28	4.68
Effective Volume (L)	1.86	2.05	2.54	2.8	3.17	3.5
Cooling system	Ventilated	Ventilated	Ventilated	Ventilated	Ventilated	Ventilated
Temperature range	3L1	3L1	3L1	3L1	3L1	3L1
Kind of Refrigerant	R404A	R404A	R404A	R404A	R404A	R404A
Cooling Capacity	1600	1760	2000	2200	2400	2640
Evaporator Fans brand	EBM	EBM	EBM	EBM	EBM	EBM
Controller Brand	CAREL	CAREL	CAREL	CAREL	CAREL	CAREL
Light	LED LIGHT	LED LIGHT	LED LIGHT	LED LIGHT	LED LIGHT	LED LIGHT
40' Container load	8	8	6	6	4	4

MULTIDECK-PLUG IN 735MM DEPTH WITH NIGHT CURTAIN

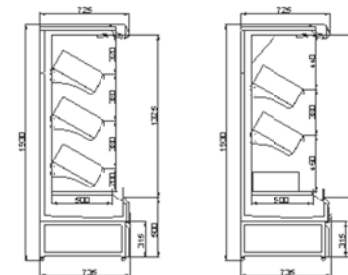

Features

- R404a refrigerant
- Low energy consumption and high cooling capacity. They are achieved by increasing evaporation temperature and heat exchange amount of efficient evaporator.
- The product is equipped with internationally famed brand compressors with high refrigeration efficiency, plug and play, easy for operation.
- Huge open space, low front edge, all maximize display effect.
- Incline shelves design, easy for display.
- Suitable size baskets, convenient for loading goods.
- LED lamp.
- Super wide night curtain minimizes the gaps between curtains to save more energy.
- Off-cycle defrost reduces energy consumption.



Product Model	BLF-1374V	BLF-2074V	BLF-2674V
UNIT Dimensions (W / D / H mm)	1310*735*1930	1935*735*1930	2560*735*1930
Packing Dimensions (W / D / H mm)	1484*845*2090	2109*845*2090	2734*845*2090
Display Area(M ²)	1.65	2.47	3.3
Effective Volume (L)	600	900	1200
Cooling System	Ventilated	Ventilated	Ventilated
Temperature range	3H1	3H1	3H1
Kind of Refrigerant	R404A	R404A	R404A
Compressor brand	CRSS	CRSS	CRSS
Evaporator Fans brand	EBM	EBM	EBM
Controller Brand	CAREL	CAREL	CAREL
Light	LED LIGHT	LED LIGHT	LED LIGHT
40' Container load	22	14	8

MULTIDECK-REMOTE 735MM DEPTH WITH NIGHT CURTAIN



Features

- R404a refrigerant.
- Low energy consumption and high cooling capacity. They are achieved by increasing evaporation temperature and heat exchange amount of efficient evaporator.
- Designedly a solenoid valve in each cabinet, in front of which a filter is installed with the purpose of guarding against blockage, reducing difficulty and time of installation.
- Smaller depth for space saving.
- Huge open space, low front edge, all maximize display effect.
- Incline shelves design, easy for display.
- Suitable size baskets, convenient for loading goods.
- LED lamp
- Super wide night curtain minimizes the gaps between curtains to save more energy.
- Top tubing design makes construction easier.
- Off-cycle defrost reduces energy consumption.
- Glass gable and solid gable for optional.

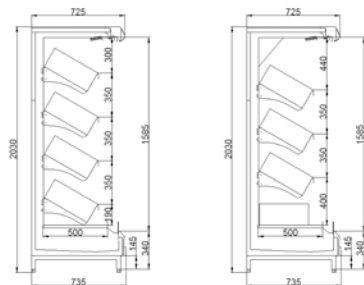

Product Model	CLF-1374V	CLF-2074V	CLF-2674V
Unit Dimension (W/D/H mm)	1310*735*1930	1935*735*1930	2560*735*1930
Packing Dimensions (W / D / H mm)	1484*845*2090	2109*845*2090	2734*845*2090
Display Area(M ²)	1.97	2.96	3.94
Effective Volume (L)	0.82	1.23	1.64
Cooling system	Ventilated	Ventilated	Ventilated
Temperature range	3HI	3HI	3HI
Kind of Refrigerant	R404A	R404A	R404A
Cooling Capacity	1755	2600	3470
Evaporator Fans brand	EBM	EBM	EBM
Controller Brand	CAREL	CAREL	CAREL
Light	LED LIGHT	LED LIGHT	LED LIGHT
40' Container load	22	14	8

MULTIDECK-REMOTE 918MM DEPTH WITH NIGHT CURTAIN



Features

- R404a refrigerant.
- Low energy consumption and high cooling capacity. They are achieved by increasing evaporation temperature and heat exchange amount of efficient evaporator.
- The product is equipped with internationally famed brand compressors with high refrigeration efficiency, plug and play, easy for operation.
- Huge open space, low front edge, all maximize display effect.
- Incline shelves design, easy for display.
- Suitable size baskets, convenient for loading goods.
- LED lamp.
- Super wide night curtain minimizes the gaps between curtains to save more energy.
- Off-cycle defrost reduces energy consumption.

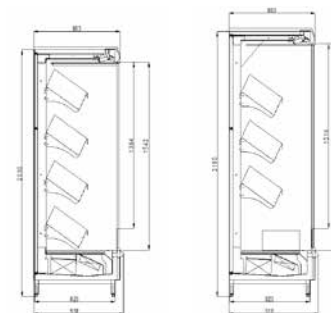

Product Model	CLF-1392V	CLF-2092VH	CLF-2592V	CLF-2592VH	CLF-3892V	CLF-3892VH
Unit Dimension (W/D/H mm)	1935*918*2030	1935*918*2180	2560*918*2030	2560*918*2180	3810*918*2030	3810*918*2180
Packing Dimensions (W / D / H mm)	2120*1100*2200	2120*1100*2200	2820*1100*2200	2820*1100*2200	4170*1100*2200	4170*1100*2200
Display Area(M ²)	2.94	3.22	3.92	4.29	5.88	6.44
Effective Volume (L)	1.6	1.74	2.14	2.33	3.21	3.49
Cooling System	Ventilated	Ventilated	Ventilated	Ventilated	Ventilated	Ventilated
Temperature range	3HI	3HI	3HI	3HI	3HI	3HI
Kind of Refrigerant	R404A	R404A	R404A	R404A	R404A	R404A
Cooling Capacity	3070	3530	3900	4480	5840	6720
Evaporator Fans brand	EBM	EBM	EBM	EBM	EBM	EBM
Controller Brand	CAREL	CAREL	CAREL	CAREL	CAREL	CAREL
Light	LED LIGHT	LED LIGHT	LED LIGHT	LED LIGHT	LED LIGHT	LED LIGHT
40' Container load	11	11	8	8	4	4

MULTIDECK PLUG-IN SEMI CABINET

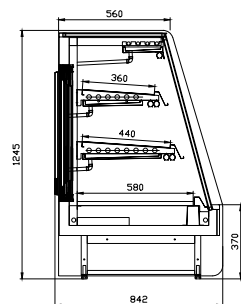

Features

- The unique design of anti-fog glass door can keep the goods can be clearly seen
- All handles barrier-free design, to meet different customer needs
- Frozen food and ice cream is suitable for exhibition
- LED lamp, energy saving province electricity



Product Model	BSF-1880	BSF-2480
Unit Dimensions(W/D/H mm)	1830*825*1460	2430*825*1460
Packing Dimensions(W/D/H mm)	1980*930*1660	2580*930*1660
Effective Volume(L)	380	520
Display area(m ²)	2.81	3.77
Temperature range(°C)	-2~-2(25°C,60%RH)	-2~-2(25°C,60%RH)
Inside shelf	3	3
Compressor	BOYANG	BOYANG
Refrigerant	R404A	R404A
Temperature control	DIXELL	DIXELL
LED lighting	LED	LED
40GP CONTAINER	12	8

MULTIDECK PLUG-IN 735MM DEEP SEMI CABINET



Features

- R404a refrigerant.
- Low energy consumption and high cooling capacity. They are achieved by increasing evaporation temperature and heat exchange amount of efficient evaporator.
- The product is equipped with internationally famed brand compressors with high refrigeration efficiency, plug and play, easy for operation.
- Huge open space, low front edge, all maximize display effect.
- More volume is achieved by maximizing shelf depth in a certain freezer width.
- LED lamp.
- Super wide night curtain minimizes the gaps between curtains to save more energy.
- Off-cycle defrost reduces energy consumption.
- Impact in size, easy to move.

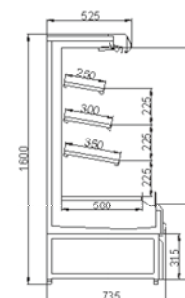

Product Model	BSF-1374	BSF-2074	BSF-2674
UNIT Dimensions (W/D/H mm)	1310*735*1600	1935*735*1600	2560*735*1600
Packing Dimensions(W/D/H mm)	1484*845*1730	2109*845*1730	2734*845*1730
Display Area(m ²)	1.29	1.93	2.50
Effective Volume(L)	390.00	590	770
Cooling System	Ventilated	Ventilated	Ventilated
Temperature range	M1/M2	M1/M2	M1/M2
Kind of Refrigerant	R404A	R404A	R404A
Compressor brand	CRSS	CRSS	CRSS
Evaporator Fans brand	EBM	EBM	EBM
Controller Brand	CAREL	CAREL	CAREL
Light	LED LIGHT	LED LIGHT	LED LIGHT
40 ' Container load	22	14	8

MULTIDECK PLUG-IN 900MM DEEP SEMI CABINET

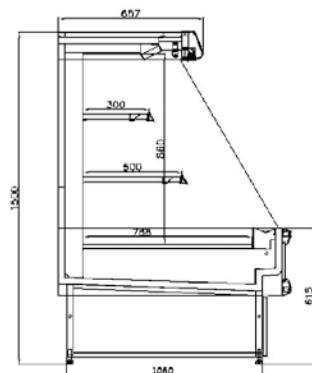

Features

- Suitable with the fruits and vegetables, deli meat, dairy products, packaging
- High-performance evaporator design, high efficient air curtain technology
- The machine one-piece, convenient put, mobile

Product Model	BSF-15110	BSF-20110	BSF-27110
UNIT Dimensions (W / D/ H mm)	1500*1060*1500	2035*1060*1500	2660*1060*1500
Packing Dimensions (W / D/ H mm)	1800*1220*1700	2250*1220*1700	2800*1220*1700
Display Area(m ²)	1.41	2.15	2.89
Effective Volume(L)	0.49	0.72	0.95
Cooling system	Ventilated	Ventilated	Ventilated
Temperature range	3M2	3M2	3M2
Kind of Refrigerant	R404A	R404A	R404A
Compressor	CRSS(SANYANG)	CRSS(SANYANG)	CRSS(SANYANG)
Evaporator Fans brand	EBM	EBM	EBM
Controller Brand	CAREL	CAREL	CAREL
Light	LED LIGHT	LED LIGHT	LED LIGHT
40' Container load	9	9	4

MULTIDECK-REMOTE 918MM DEEP SEMI CABINET



Features

- R404a refrigerant.
- Low energy consumption and high cooling capacity. They are achieved by increasing evaporation temperature and heat exchange amount of efficient evaporator.
- Designedly a solenoid valve in each cabinet, in front of which a filter is installed with the purpose of guarding against blockage, reducing difficulty and time of installation.
- Smaller depth for space saving.
- Huge open space ,low front edge, all maximize display effect.
- Incline shelves design, easy for display.
- Suitable size baskets, convenient for loading goods.
- LED lamp
- Super wide night curtain minimizes the gaps between curtains to save more energy.
- Top tubing design makes construction easier.
- Off-cycle defrost reduces energy consumption.
- Glass gable and solid gable for optional.

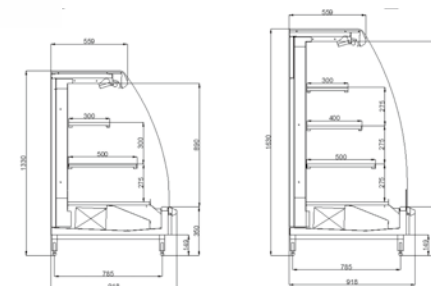

Product Model	CSF-1892	CSF-1892L	CSF-2592	CSF-2592L	CSF-3792	CSF-3792L
Unit Dimension (W/D/H mm)	1935*918*1600	1935*918*1300	2560*918*1600	2560*918*1300	3810*918*1600	3810*918*1300
Packing Dimensions (W / D/ H mm)	2120*1100*2200	2110*995*1480	2820*1100*2200	2735*995*1480	4170*1100*2200	4005*995*1480
Display Area(M ²)	2.47	1.91	3.29	2.54	4.94	3.81
Effective Volume (L)	0.97	0.72	1.3	0.96	1.94	1.44
Cooling system	Ventilated	Ventilated	Ventilated	Ventilated	Ventilated	Ventilated
Temperature range	3M1	3M1	3M1	3M1	3M1	3M1
Kind of Refrigerant	R404A	R404A	R404A	R404A	R404A	R404A
Evaporator Fans brand	EBM	EBM	EBM	EBM	EBM	EBM
Controller Brand	CAREL	CAREL	CAREL	CAREL	CAREL	CAREL
Light	LED LIGHT	LED LIGHT	LED LIGHT	LED LIGHT	LED LIGHT	LED LIGHT
40' Container load	10	10	8	8	6	6

MULTIDECK-PLUG IN AND REMOTE MINI RING CABINET



BRF-1712 (RM)



BRF-1712 (PI)

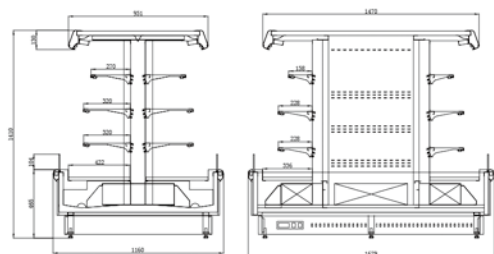

Features

- Frozen food surround type were displayed
- Completely transparent glass partition
- Streamline design
- LED lighting

Product Model	BRF-1712(RM)	BRF-1712(PI)
Unit Dimension (W/D/H mm)	1680*1160*1450	1680*1160*1450
Packing Dimensions (W / D/ H mm)	1880*1320*1650	1880*1320*1650
Display Area(M2)	3.5	3.15
Effective Volume (L)	0.91	0.82
Cooling system	Ventilated	Ventilated
Temperature range	3M2	3M2
Kind of Refrigerant	R404A	R404A
Compressor brand	Without	CRSS(SANYANG)
Evaporator Fans brand	EBM	EBM
Controller Brand	CAREL	CAREL
Light	LED LIGHT	LED LIGHT
40' Container load	9	9

MULTIDECK-REMOTE RING CABINET



Features

- The unique design of anti-fog glass door can keep the goods can be clearly seen
- All handles barrier-free design, to meet different customer needs
- Frozen food and ice cream is suitable for exhibition
- LED lamp, energy saving province electricity

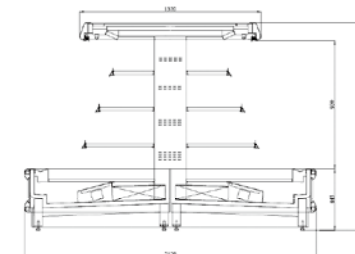

Product Model	CRF-22110D	CRF-19110	CRF-25110	CRF-38110
Unit Dimension (W/D/H mm)	2120*1060*1500	1875*1060*1500	2500*1060*1500	3750*1060*1500
Packing Dimensions (W / D/ H mm)	2220*1160*1700	2075*1160*1700	2780*1160*1700	3950*1160*1700
Display Area(M2)	4.43	3.68	5.22	7.46
Effective Volume (L)	0.62	0.71	0.94	1.49
Cooling system	Ventilated	Ventilated	Ventilated	Ventilated
Temperature range	3M2	3M2	3M2	3M2
Kind of Refrigerant	R404A	R404A	R404A	R404A
Compressor brand	2200	1900	2200	3300
Evaporator Fans brand	EBM	EBM	EBM	EBM
Controller Brand	CAREL	CAREL	CAREL	CAREL
Light	LED LIGHT	LED LIGHT	LED LIGHT	LED LIGHT
40' Container load	10	11	8	6

MULTIDECK-REMOTE SEMI CABINET

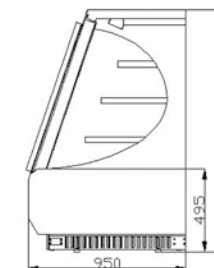
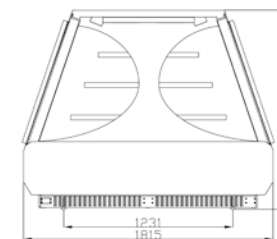

Features

- A more transparent display
- Digital controller
- Finned evaporator
- Thermostatic expansion valve
- Automatic defrost
- LED light for every door
- Adjustable shelves
- With price label setting
- Automatic drain water
- R404A
- Side double tempered glass



Product Model	RSG-2018	RSG-2618	RSG-3818	RSG-2009	RSG-2609	RSG-3809
Unit Dimension (W/D/H mm)	1963*1815*1450	2588*1815*1450	3838*1815*1450	1963*950*1450	2588*950*1450	3838*950*1450
Packing Dimension (W/D/H mm)	2063*1915*1550	2688*1915*1550	3938*1915*1550	2063*1050*1550	2688*1050*1550	3938*1050*1550
Effective Volume(M ³)	4.12	5.49	8.24	2.06	2.75	4.12
Display Area(M ²)	12	16	24	6	8	12
Cooling System	VENTILATED	VENTILATED	VENTILATED	VENTILATED	VENTILATED	VENTILATED
Light	Vertical LED light	Vertical LED light	Vertical LED light	Vertical LED light	Vertical LED light	Vertical LED light
Glass Door No.	6	8	10	3	4	5
Temperature (°C)	≤ -18	≤ -18	≤ -18	≤ -18	≤ -18	≤ -18
Kind of Coolant	R404a	R404a	R404a	R404a	R404a	R404a
40 GP Container Loading (Pcs)	6	4	3	11	9	6

MULTIDECK-PLUG IN

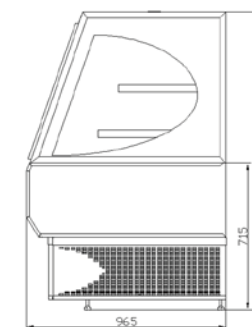
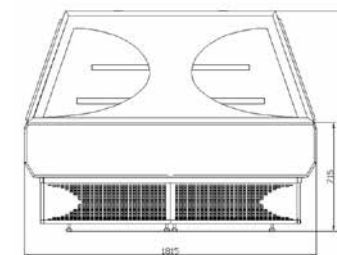

Features

- A more transparent display
- Digital controller
- Finned evaporator
- Thermostatic expansion valve
- Automatic defrost
- LED light for every door
- Adjustable shelves
- With price label setting
- Automatic drain water
- R404A
- Side double tempered glass



Product Model	PSG-I06	PSG-I08	PSGW-06	PSGW-08	PSGW-12
Unit Dimension (W/D/H mm)	1963*1815*1450	2588*1815*1450	1963*950*1450	2588*950*1450	3838*950*1450
Packing Dimension (W/D/H mm)	2063*1915*1550	2688*1915*1550	2063*1050*1550	2688*1050*1550	3938*1050*1550
Cooling system	VENTILATED	VENTILATED	VENTILATED	VENTILATED	VENTILATED
Effective Volume(M3)	1.23	1.64	0.62	0.82	1.23
Display Area(M2)	3.3	4.4	1.65	2.2	3.3
Kind of coolant	R404A	R404A	R404A	R404A	R404A
Temperature (°C)	≤ -18	≤ -18	≤ -18	≤ -18	≤ -18
Number of door	6	8	3	4	5
Light	Vertical LED light	Vertical LED light	Vertical LED light	Vertical LED light	Vertical LED light
40 GP Container Loading (Pcs)	6	4	11	9	6

QINGDAO SANTA INTERNATIONAL CO.,LTD

COMBINED ISLAND FREEZER



CQH-22L



Features

- Super size straight line Island freezer
- Exterior material: white pre-coated steel, Interior white pre-painted aluminium sheet
- Top curved sliding glass lid with low-E film
- Automatic hot gas defrost
- Condensing with fan
- High quality danfoss compressor
- Italian brand Eliwell/Dixell digital thermostat
- Interior LED light
- Full Basket with dividers

Options

- Front side protection pole
- Adjustable feet
- Caster wheels

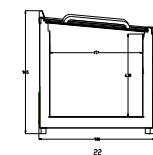

22

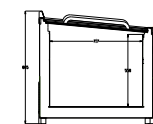

19

Product Model	CQH-19D	CQH-19L	CQH-22L
Unit Dimensions (W / D / H mm)	1915x900x855	1905x900x935	2205x900x935
Pack Dimensions (W / D / H mm)	2025x995x885	2025x995x965	2325x995x965
Net capacity (L)	685	800	955
Defrost system	Automatic	Automatic	Automatic
Temperature (°C)	3L1	3L1	3L1
Baskets divider	2+1	2+1	3+1
Interior light	LED Light	LED Light	LED Light
Compressor	Secop	Secop	Secop
Digital thermostat	Dixell/Elitech	Dixell/Elitech	Dixell/Elitech
Kind of coolant	R290	R290	R290
40' Container loading	36	24	24

COMBINED ISLAND FREEZER DOUBLE CIRCULAR ARC

CE



SDC-500

Features

- Super size straight line Island freezer.
- Exterior material: white pre-coated steel, Interior white prepainted aluminium sheet.
- Top curved sliding glass lid with low-E film.
- Automatic hot gas defrost.
- Condensing with fan.
- High quality danfoss compressor.
- Italian brand Eliwell/Dixell digital thermostat.
- Interior LED light.
- Full Basket with dividers.

Options

- Front side protection pole
- Adjustable feet
- Caster wheels

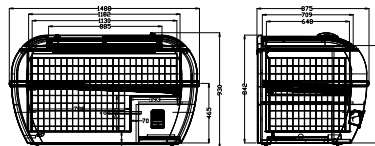

Product Model	SDC-500
Unit Dimensions (W / D/ H)mm	1500*880*980
Packing Dimensions (W / D/ H)mm	1560*980*1150
Net capacity (L)	340
Defrost system	Automatic
Temperature (°C)	3L1
Baskets divider	2+1
Interior light	LED Light
Compressor	Secop
Digital thermostat	Dixell/Elitech
Kind of coolant	R404A/R290
40' Container loading	30

COMBINED ISLAND FREEZER DOUBLE CIRCULAR ARC

CE



SDC-1400

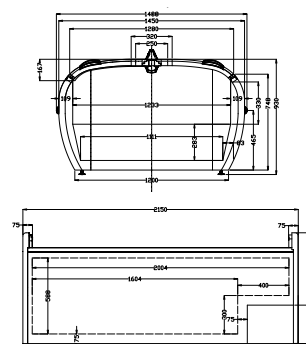

Features

- Super size straight line Island freezer.
- Exterior material: white pre-coated steel, Interior white prepainted aluminium sheet.
- Top curved sliding glass lid with low-E film.
- Automatic hot gas defrost.
- Condensing with fan.
- High quality danfoss compressor.
- Italian brand Eliwell/Dixell digital thermostat.
- Interior LED light.
- Full Basket with dividers.

Options

- Front side protection pole
- Adjustable feet
- Caster wheels

Product Model	SDC-1400
Unit Dimensions (W / D/ H)mm	2200x1500x980
Packing Dimensions (W / D/ H)mm	2320x1620x1150
Net capacity (L)	1255
Defrost system	Automatic
Temperature (°C)	3L1
Baskets divider	3+1
Interior light	LED Light
Compressor	Secop*2
Digital thermostat	Dixell/Elitech
Kind of coolant	R404A/R290
40' Container loading	14

COMBINED ISLAND FREEZER DOUBLE CIRCULAR ARC

CE



SDC-760R

Features

- Exterior material: white pre-coated steel, Interior white prepainted aluminium sheet
- Top curved sliding glass lid with low-E film
- Automatic hot gas defrost
- Condensing with fan
- High quality compressor
- Italian brand Eliwell/Dixell digital thermostat
- Interior double LED lights
- Full Basket with dividers
- Front side protection pole
- Adjustable feet

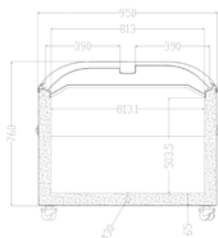

Product Model	SDC-760R
Unit Dimensions (W / D/ H)mm	1900*980*835
Packing Dimensions (W / D/ H)mm	2000*1080*870
Total net capacity (L)	580
Defrosting	Automatic
Kind of coolant	R404a/R290
Compressor	Embraco/Secop
Temperature (°C)	3L1
Water collector	Hot gas pipe for auto condensate water
Interior light	2 Sides LED light
Digital thermostat	Dixell/Eliwell
40' Container load	33

COMBINED ISLAND FREEZER DOUBLE CIRCULAR ARC

CE



SDC-780R

Features

- Exterior material: white pre-coated steel, Interior white prepainted aluminium sheet
- Top curved sliding glass lid with low-E film
- Automatic hot gas defrost
- Condensing with fan
- High quality compressor
- Italian brand Eliwell/Dixell digital thermostat
- Interior double LED lights
- Full Basket with dividers
- Front side protection pole
- Adjustable feet

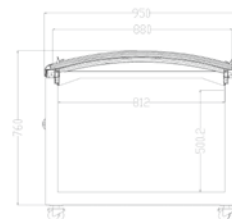

Product Model	SDC-780R
Unit Dimensions (W / D/ H)mm	1900*980*835
Packing Dimensions (W / D/ H)mm	2000*1080*870
Total net capacity (L)	580
Defrosting	Automatic
Kind of coolant	R404a/R290
Compressor	Embraco/Secop
Temperature (°C)	3L1
Water collector	Hot gas pipe for auto condensate water
Interior light	2 Sides LED light
Digital thermostat	Dixell/Eliwell
40' Container load	33

COMBINED ISLAND FREEZER WITH SLIDING GLASS TOP (UP-DOWN)



CQZ-21L



CQZ-18D

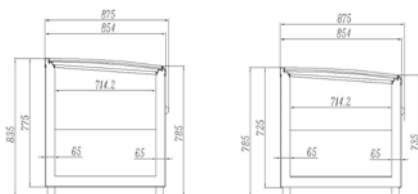

Features

- Super size straight line Island freezer
- Exterior material: white pre-coated steel, Interior white pre-painted aluminium sheet
- Top curved sliding glass lid with low-E film
- Automatic hot gas defrost
- Condensing with fan
- High quality danfoss compressor
- Italian brand Eliwell/Dixell digital thermostat
- Interior LED light
- Full Basket with dividers
- Front side protection pole
- Adjustable feet
- Caster wheels

Product Model	CQZ-18D	CQZ-21L	CQZ-25L
Unit Dimensions (W / D/ H mm)	1850*854*785	2105*875*835	2505*854*835
Pack Dimensions (W / D/ H mm)	1940*1040*870	2280*1040*870	2680*1040*870
Net capacity (L)	400	460	540
Defrost system	Automatic	Automatic	Automatic
Temperature (°C)	3L1	3L1	3L1
Baskets divider	3+1	4+1	5+1
Interior light	LED Light	LED Light	LED Light
Compressor	Secop/Embraco	Secop/Embraco	Secop/Embraco
Digital thermostat	Dixell/Elitech	Dixell/Elitech	Dixell/Elitech
Kind of coolant	R404A/R290	R404A/R290	R404A/R290
40' Container loading	35	33	24

COMBINED ISLAND FREEZER WITH SLIDING GLASS TOP (LEFT-RIGHT)



CQS-18D



CQS-21L

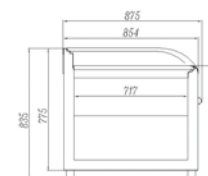

Features

- Super size straight line Island freezer
- Exterior material: white pre-coated steel, Interior white pre-painted aluminium sheet
- Top curved sliding glass lid with low-E film
- Automatic hot gas defrost
- Condensing with fan
- High quality danfoss compressor
- Italian brand Eliwell/Dixell digital thermostat
- Interior LED light
- Full Basket with dividers
- Front side protection pole
- Adjustable feet
- Caster wheels

Product Model	CQS-18D	CQS-21L	CQS-25L
Unit Dimensions (W/D/H mm)	1860*854*835	2105*875*835	2505*854*835
Pack Dimensions (W / D/ H mm)	1940*1040*870	2280*1040*870	2680*1040*870
Net capacity (L)	400	460	540
Defrost system	Automatic	Automatic	Automatic
Temperature (°C)	3L1	3L1	3L1
Baskets divider	3+1	4+1	5+1
Interior light	LED Light	LED Light	LED Light
Compressor	Embraco/Secop	Embraco/Secop	Embraco/Secop
Digital thermostat	Eliwell/Dixell	Eliwell/Dixell	Eliwell/Dixell
Kind of coolant	R404A/R290	R404A/R290	R404A/R290
40' Container loading	35	33	24

ISLAND FREEZER



LD-236

Features

- Island freezer
- 236L
- Store frozen food and ice cream
- Top double layer sliding temperglass lid
- Ext white prepainted steel,int embossed AL
- Bottom engine room with fan assisted
- Caster wheels



Product Model	LD-236	LD-358	LD-426	LD-528
Unit Dimensions(W/D/H mm)	1340*655*765	1505*715*870	1785*735*825	1895*850*870
Net capacity(L)	236	358	426	528
Cooling system	static	static	static	static
Temperature (°C)	≤-15	≤-15	≤-15	≤-15
Basket No.	2	4	3	6
Defrosting	Manual	Manual	Manual	Manual
Compressor	LG	LG	LG	LG
Kind of coolant	R134a	R134a	R134a	R134a
40'Container loading	75(40HQ)	44	36	24

ISLAND FREEZER



SDG-2.0

Features

- Island freezer
- 588L
- Store frozen food and ice cream
- Top double layer sliding temperglass lid
- Ext white prepainted steel,int embossed AL
- Bottom engine room with fan assisted
- Caster wheels



Product Model	SDG-2.0	SDG-2.2	SDG-2.5	SCD-316	SCD-386
Unit Dimensions (W/D/H mm)	2030*780*910	2000*1000*865	2530*995*865	1850*810*760	1960*960*760
Net capacity(L)	588	718	878	316	386
Cooling system	static	static	static	static	static
Temperature (°C)	≤-15	≤-15	≤-15	-6~12	-6~12
Basket No.	6	6	9	3	3
Defrosting	Manual	Manual	Manual	Manual	Manual
Compressor	LG	LG	LG	LG	LG
Kind of coolant	R134a	R134a	R134a	R134a	R134a
40'Container loading	26	22	18	24	24

ISLAND FREEZER



SD-900

Features

- Island freezer
- Store frozen food and ice cream
- Top double layer sliding temperglass lid
- Ext white prepainted steel,int embossed AL
- Bottom engine room with fan assisted
- Caster wheels



Product Model	SD-700	SD-900
Unit Dimensions (W / D/ H mm)	1750×810×840	1900×900×840
Packing Dimensions (W / D/ H mm)	1830×890×890	1980×970×890
Cooling system	Static	Static
Climate class	ST	ST
Total net capacity	710L	885L
Compressor	Wansheng	Wansheng
Kind of coolant	R290	R290
Temperature Control Range	≤18°C	≤18°C
Insulation	65mm	65mm
Glass Door (lid) Number	2	3
40 ' HC Container load	39EA	36EA

ISLAND FREEZER DOUBLE TEMPERATURE & VENTILATED FREEZER



Features

- The operation temperature of 3M1,3L2 two temperature zone, used for display and sales of refrigerated seafood, meat and so on; for display and sale of frozen fish frozen, frozen meat and frozen food.
- the use of international brand-name SECOP compressor, high cooling efficiency, plug and play, easy to use
- low temperature dual temperature dual control, users can adjust according to demand
- polyurethane cavity integral foaming process to reduce cold consumption and reduce energy consumption
- ultra-thin large area high-performance evaporator, cooling fast, effective volume
- installation of self evaporation water receiver, convenient to use, save worry

Options

- with door

Product Model	DII-240	DII-320	DII-410
Unit Dimensions (W / D/ H mm)	1530*995*950	2030*995*950	2530*995*950
Packing Dimensions (W / D/ H mm)	1630*1100*1050	2130*1100*1050	2630*1100*1050
Display area(m ²)	1.03	1.4	1.78
Defrost	Automatic	Automatic	Automatic
Total net capacity(L)	260	350	440
Kind of coolant	R404a	R404a	R404a
Cooling system	VENTILATDE	VENTILATDE	VENTILATDE
Temperature Control Range	3M1&3L1	3M1&3L1	3M1&3L1
Thermostat	CAREL	CAREL	CAREL
Compressor	SECOP	SECOP	SECOP
Light	no	no	no
40 ' HC Container load	28	20	16

ISLAND FREEZER SINGLE VENTILATED



Features

- The unique evaporator coil design energy efficiency
- Efficient extrusion air curtain design
- Island cabinet glass door can choose push or pull up and down or so push-pull

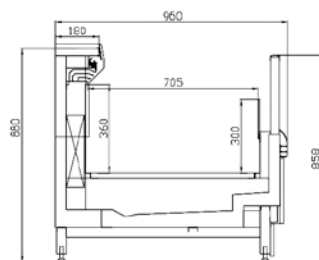

Product Model	SV-1910	SV-2510	SV-3810
Unit Dimension (W/D/H mm)	1875*960*850	2500*960*850	3750*960*850
Packing Dimensions (W / D/ H mm)	2170*1100*1050	2800*1100*1050	3950*1100*1050
Display Area(M2)	2.01	2.71	4.06
Effective Volume (L)	650	820	1420
Cooling system	Ventilated	Ventilated	Ventilated
Temperature range	3L1	3L1	3L1
Kind of Refrigerant	R404A	R404A	R404A
Cooling Capacity	800	1100	1600
Evaporator Fans brand	EBM	EBM	EBM
Controller Brand	CAREL	CAREL	CAREL
Light	LED LIGHT	LED LIGHT	LED LIGHT
40' Container load	10	16	12

ISLAND FREEZER DOUBLE VENTILATED



Features

- The unique evaporator coil design energy efficiency
- Efficient extrusion air curtain design
- Island cabinet glass door can choose push or pull up and down or so push-pull
- The cold shelver optional
- Different width of 1550 mm and 1800 mm optional

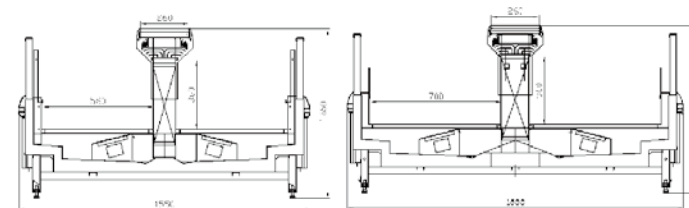

Product Model	DV-1918	BV-2518	DV-3818	DV-1810D	DV-1916	BV-2516	DV-3816	DV-1610D
Unit Dimension (W/D/H mm)	1875*1800*850	2500*1800*850	3750*1800*850	1800*960*850	1875*1550*850	2500*1550*850	3750*1550*850	1550*960*850
Packing Dimensions (W / D/ H mm)	2170*2000*1050	2800*2000*1050	3950*2000*1050	2000*1100*1050	2170*1700*1050	2800*1700*1050	3950*1700*1050	1700*1100*1050
Display Area(M2)	3.81	5.08	7.63	1.96	3.38	4.52	6.78	1.73
Effective Volume (L)	870	1180	1790	340	620	1050	1580	200
Cooling system	Ventilated	Ventilated	Ventilated	Ventilated	Ventilated	Ventilated	Ventilated	Ventilated
Temperature range	3L1	3L1	3L1	3L1	3L1	3L1	3L1	3L1
Kind of Refrigerant	R404A	R404A	R404A	R404A	R404A	R404A	R404A	R404A
Cooling Capacity	1200	1600	2400	800	1100	1400	2100	700
Evaporator Fans brand	EBM	EBM	EBM	EBM	EBM	EBM	EBM	EBM
Controller Brand	CAREL	CAREL	CAREL	CAREL	CAREL	CAREL	CAREL	CAREL
Light	LED LIGHT	LED LIGHT	LED LIGHT	LED LIGHT	LED LIGHT	LED LIGHT	LED LIGHT	LED LIGHT
40' Container load	12	8	6	24	14	8	6	28

COMBINET CABINET

UP-1200F



SD-420Q

Features

- Temperature: -18~-21°C.
- Automatic defrost.
- Automatic evaporation of defrosting water.
- Digital thermostat
- Inside LED lamp.
- Good display effect
- Suspension structure to save space
- Adjustable shelves

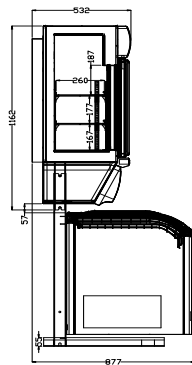

COMBINET CABINET

UP-2100F



CQS-21L

Features

- Temperature: -18~-21°C.
- Automatic defrost.
- Automatic evaporation of defrosting water.
- Digital thermostat
- Inside LED lamp.
- Good display effect
- Suspension structure to save space
- Adjustable shelves

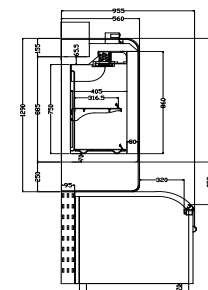

Product Model	UP-1200C	UP-1200F	SD-420Q
Unit Dimension (W/D/H mm)	1275*532*1162	1275*532*1162	1270*680*850
Packing Dimension (W/D/H mm)	1380*760*1320	1380*760*1320	1320*780*890
Effective Volume(M ³)	250	250	355
Display Area(M ²)	0.47	0.47	/
Cooling System	Ventilated	Ventilated	STATIC
Light	LED LIGHT	LED LIGHT	LED
Glass Door No.	2	2	4
Temperature (°C)	M1	L1	-18~-21°C
Compressor	SECOP/EMBRACO	SECOP/EMBRACO	ZEL
Kind of Coolant	R290/R404A	R290/R404A	R290
40 GP Container Loading (Pcs)	52	52	79

COMBINET CABINET

UP-2100F



CQS-21L

Features

- Temperature: -18~-21°C.
- Automatic defrost.
- Automatic evaporation of defrosting water.
- Digital thermostat
- Inside LED lamp.
- Good display effect
- Suspension structure to save space
- Adjustable shelves

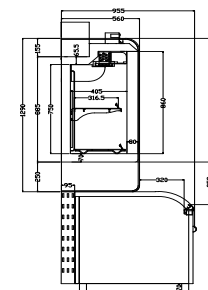

Product Model	UP-2100F	CQS-21L
Unit Dimension (W/D/H mm)	2160*560*1460	2105*875*835
Packing Dimension (W/D/H mm)	1380*760*1320	2280*1040*870
Effective Volume(M ³)	1200	460
Display Area(M ²)	0.56	1.84
Cooling System	Ventilated	STATIC
Light	LED LIGHT	LED LIGHT
Temperature (°C)	L1/L2	L1/L2
Glass Door No.	3	2
Compressor	SECOP/EMBRACO	SECOP/EMBRACO
Kind of Coolant	R290/R404A	R290/R404A
40 GP Container Loading (Pcs)	17	33

SERVICE OVER COUNTER PLUG-IN



Features

- Stylish serve over counters for display of a variety of foodstuffs, dairy products, sausages, packaged meats & poultry and delicatessens
- Ensures maximum visibility to the products presented
- Front glass can be opened



BSS-2090SG

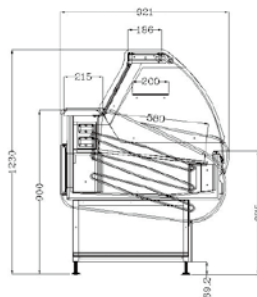

Product Model	BSS-1290SG	BSS-1590SG	BSS-2090SG	BSS-2590SG
Unit Dimensions (W/D/H mm)	1340*918*1230	1590*918*1230	1965*918*1230	2590*918*1230
Packing Dimensions (W/D/H mm)	1440*982*1277	1690*980*1300	2085*980*1300	2710*980*1300
Display Area (m ²)	1.25	1.51	1.89	2.52
Cooling system	Ventilated cooling	Ventilated cooling	Ventilated cooling	Ventilated cooling
Digital thermostat	DIXCELL	DIXELL	DIXELL	DIXELL
Light	LED	LED	LED	LED
Effective Volume (L)	110	130	158	208
Temperature (°C)	-2~-2	-2~+2	-2~-2	-2~-2
Compressor	Embraco/Secop	Embraco/Secop	Embraco/Secop	Embraco/Secop
Kind of coolant	R404a/R290	R404a/R290	R404a/R290	R404a/R290
40' Container loading	32	28	24	16

SERVICE OVER COUNTER PLUG-IN



BSS-2090RG

Features

- Exterior material pre-coated plate, interior stainless steel
- Inner box curved edges for easy cleaning
- Magnetic sealing strip keeps the cold air inside. Easy to remove without use of tools
- Digital thermostat Italian famous brand
- Dixell, Carel, Eliwell
- High quality famous compressor: Secop
- Internal LED light

Features

- Fans: Germany Well-known brand EBM fans
- Automatic defrost cooling system
- Adjustable stainless steel feet or lockable castors
- Special various front panel design according to customer request

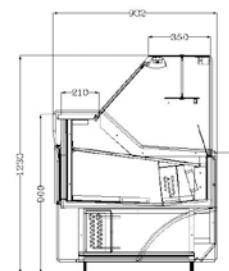

Product Model	BSS-1590RG	BSS-1590RG	BSS-2090RG	BSS-2590RG
Unit Dimensions (W/D/H mm)	1340*902*1230	1590*902*1230	1965*902*1230	2590*902*1230
Packing Dimensions (W/D/H mm)	1440*982*1287	1690*980*1300	2085*980*1300	2710*980*1300
Display Area (m ²)	1.25	1.51	1.89	2.52
Cooling system	Ventilated cooling	Ventilated cooling	Ventilated cooling	Ventilated cooling
Digital thermostat	DIXCELL	DIXCELL	DIXCELL	DIXCELL
Light	LED	LED	LED	LED
Effective Volume (L)	110	130	158	208
Temperature (°C)	-2~-2	-2~-2	-2~-2	-2~-2
Compressor	Embraco/Secop	Embraco/Secop	Embraco/Secop	Embraco/Secop
Kind of coolant	R404a/R290	R404a/R290	R404a/R290	R404a/R290
40' Container loading	32	28	24	16

SERVICE OVER COUNTER PLUG-IN&REMOTE



Features

- The appearance looks nice and elegant,the display effect is excellent
- R404a/R744 reftigerant.
- Off-cycle defrost, reduces the energy consumption.
- The product uses high efficient evaporator,it increases the heat exchange rate,the refrigeration power is large.
- There is a solenoid valve for each cabinet. We put a filter in front of the solenoid valve to reduce the difficulty and period of installation,limit the risk of dirt blockage.
- Optional high efficiency fan can be selected according to customers' requirement.
- The glass lifting structure se damping air pump spring,glass can be stopped at any angle.it's a convenient design for retuel and other daily work.

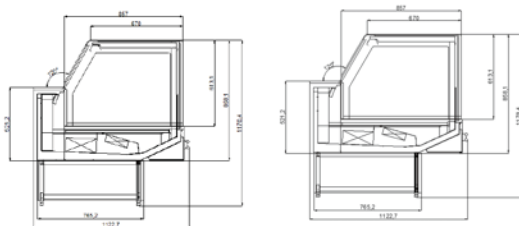

Product Model	BSS-2011SGA/ CSS-2011SGA	BSS-2511SGA/ CSS-2511SGA	BSS-3811SGA/ CSS-3811SGA
Unit Dimension (W/D/H mm)	1875*1103*1145	2500*1103*1145	3750*1103*1600
Packing Dimensions (W / D / H mm)	2075*1250*1280	2700*1250*1280	3950*1250*1280
Display Area(M2)	1.38	1.84	2.76
Effective Volume (L)	330	440	670
Cooling system	Ventilated	Ventilated	Ventilated
Temperature range	3M1	3M1	3M1
Kind of Refrigerant	R404A	R404A	R404A
Compressor brand	SECOP/WITHOUT COMPRESSOR	SECOP/WITHOUT COMPRESSOR	SECOP/WITHOUT COMPRESSOR
Evaporator Fans brand	EBM	EBM	EBM
Controller Brand	CAREL	CAREL	CAREL
Light	LED LIGHT	LED LIGHT	LED LIGHT
40' Container load	18	8	6

SELF SERVICE COUNTER PLUG-IN&REMOTE



Features

- The appearance looks nice and elegant,the display effect is excellent
- R404a/R744 reftigerant.
- Off-cycle defrost, reduces the energy consumption.
- The product uses high efficient evaporator,it increases the heat exchange rate,the refrigeration power is large.
- There is a solenoid valve for each cabinet. We put a filter in front of the solenoid valve to reduce the difficulty and period of installation,limit the risk of dirt blockage.
- Optional high efficiency fan can be selected according to customers' requirement.
- The display effect is good,easy to get or restock products.

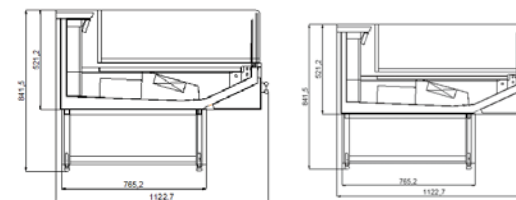

Product Model	BSM-2011SA/ CSM-2011SA	BSM-2511SA/ CSM-2511SA	BSM-3811SA/ CSM-3811SA
Unit Dimension (W/D/H mm)	1935*1103*842	2560*1103*842	3810*1103*842
Packing Dimensions (W / D / H mm)	2075*1250*980	2700*1250*980	3950*1250*980
Display Area(M2)	1.73	2.30	3.46
Effective Volume (L)	330	440	670
Cooling system	Ventilated	Ventilated	Ventilated
Temperature range	3M1	3M1	3M1
Kind of Refrigerant	R404A	R404A	R404A
Compressor brand	SECOP/WITHOUT COMPRESSOR	SECOP/WITHOUT COMPRESSOR	SECOP/WITHOUT COMPRESSOR
Evaporator Fans brand	EBM	EBM	EBM
Controller Brand	CAREL	CAREL	CAREL
Light	LED LIGHT	LED LIGHT	LED LIGHT
40' Container load	18	8	6

SERVICE OVER COUNTER PLUG-IN&REMOTE

CE

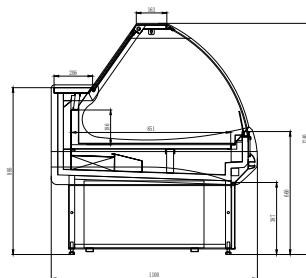

Features

- Stylish serve over counters for display of a variety of foodstuffs,dairy products,sausages,packaged meats & poultry and delicatessens.
- Ensures maximum visibility to the products presented
- Special air curtain technology,keeping food fresh ,not damage.
- Front glass can be closed.
- BSS type with compressor.
- CSS type without compressor.

Product Model	BSS-1311RGA/ CSS-1311RGA	BSS-1811RGA/ CSS-1811RGA	BSS-2511RGA/ CSS-2511RGA	BSS-3811RGA/ CSS-3811RGA
Unit Dimension (W/D/H mm)	1350*1100*1240	1980*1100*1240	2600*1100*1240	3850*1100*1240
Packing Dimensions (W / D/ H mm)	1550*1160*1400	2180*1160*1400	2800*1160*1400	4050*1160*1400
Display Area(M ²)	1.1	1.6	2.12	3.08
Effective Volume (L)	290	410	520	710
Cooling system	Ventilated	Ventilated	Ventilated	Ventilated
Temperature range	3M1	3M1	3M1	3M1
Kind of Refrigerant	R404A	R404A	R404A	R404A
Compressor brand	SECOP/WITHOUT COMPRESSOR	SECOP/WITHOUT COMPRESSOR	SECOP/WITHOUT COMPRESSOR	SECOP/WITHOUT COMPRESSOR
Evaporator Fans brand	EBM	EBM	EBM	EBM
Controller Brand	CAREL	CAREL	CAREL	CAREL
Light	LED LIGHT	LED LIGHT	LED LIGHT	LED LIGHT
40' Container load	14	10	8	6

SERVICE OVER COUNTER PLUG-IN&REMOTE

CE

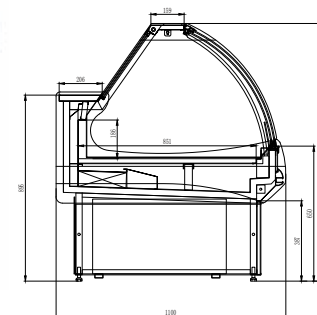

Features

- Stylish serve over counters for display of a variety of foodstuffs,dairy products,sausages,packaged meats&poultry and delicatessens.
- Ensures maximum visibility to the products presented.
- Special air curtain technology,keeping food fresh ,notdamage.
- Front glass can be pushable.
- BSS type with compressor.
- CSS type without compressor.

Product Model	BSS-1311RGB/ CSS-1311RGB	BSS-1811RGB/ CSS-1811RGB	BSS-2511RGB/ CSS-2511RGB	BSS-3811RGB/ CSS-3811RGB
Unit Dimension (W/D/H mm)	1350*1100*1240	1980*1100*1240	2600*1100*1240	3850*1100*1240
Packing Dimensions (W / D/ H mm)	1550*1160*1400	2180*1160*1400	2800*1160*1400	4050*1160*1400
Display Area(M ²)	1.1	1.6	2.12	3.08
Effective Volume (L)	290	410	520	710
Cooling system	Ventilated	Ventilated	Ventilated	Ventilated
Temperature range	3M1	3M1	3M1	3M1
Kind of Refrigerant	R404A	R404A	R404A	R404A
Compressor brand	SECOP/WITHOUT COMPRESSOR	SECOP/WITHOUT COMPRESSOR	SECOP/WITHOUT COMPRESSOR	SECOP/WITHOUT COMPRESSOR
Evaporator Fans brand	EBM	EBM	EBM	EBM
Controller Brand	CAREL	CAREL	CAREL	CAREL
Light	LED LIGHT	LED LIGHT	LED LIGHT	LED LIGHT
40' Container load	14	10	8	6

SERVICE OVER COUNTER PLUG-IN&REMOTE



CSS-2511RGC

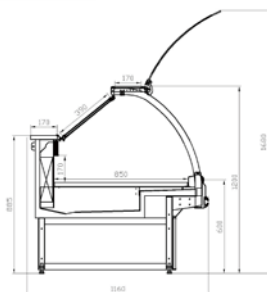

Features

- Stylish serve over counters for display of a variety of foodstuffs,dairy products,sausages,packaged meats & poultry and delicatessens.
- Ensures maximum visibility to the products presented
- Special air cutrain technology,keeping food fresh ,not dam.age.
- Front glass can be opened.
- BSS type with compressor.
- CSS type without compressor.

Product Model	BSS-1311RGC/ CSS-1311RGC	BSS-1811RGC/ CSS-1811RGC	BSS-2511RGC/ CSS-2511RGC	BSS-3811RGC/ CSS-3811RGC
Unit Dimension (W/D/H mm)	1336*1160*1200	1960*1160*1200	2560*1160*1200	3836*1160*1200
Packing Dimensions (W /D/ H mm)	1450*1260*1400	2070*1260*1400	2710*1260*1400	3950*1260*1400
Display Area(M ²)	1.1	1.6	2.12	3.08
Effective Volume (L)	320	390	530	750
Cooling system	Ventilated	Ventilated	Ventilated	Ventilated
Temperature range	3M1	3M1	3M1	3M1
Kind of Refrigerant	R404A	R404A	R404A	R404A
Compressor brand	SECOP/WITHOUT COMPRESSOR	SECOP/WITHOUT COMPRESSOR	SECOP/WITHOUT COMPRESSOR	SECOP/WITHOUT COMPRESSOR
Evaporator Fans brand	EBM	EBM	EBM	EBM
Controller Brand	CAREL	CAREL	CAREL	CAREL
Light	LED LIGHT	LED LIGHT	LED LIGHT	LED LIGHT
40 ' Container load	9	9	4	3

SELF SERVICE COUNTER PLUG-IN&REMOTE



Features

- Suitable for cold fresh meat, vegetables products.
- Dafoss valves, import compressor.
- Ark of straight stitching, roundabout splicing.
- Stainless steel shelf, clean, heath, easy to clean.

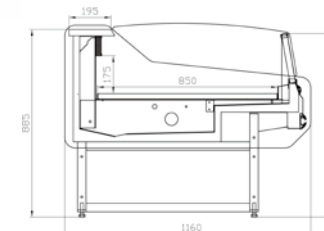

Product Model	BSM-1311RC/ CSM-1311RC	BSM-2011RC/ CSM-2011RC	BSM-2511RC/ CSM-2511RC	BSM-3811RC/ CSM-3811RC
Unit Dimension (W/D/H mm)	1336*1160*900	1960*1160*900	2580*1160*900	3836*1160*900
Packing Dimensions (W / D/ H mm)	1500*1260*1100	2100*1260*1100	2700*1260*1100	3950*1260*1100
Display Area(M ²)	1.1	1.6	2.12	3.08
Effective Volume (L)	290	410	530	750
Cooling system	Ventilated	Ventilated	Ventilated	Ventilated
Temperature range	3M1	3M1	3M1	3M1
Kind of Refrigerant	R404A	R404A	R404A	R404A
Compressor brand	SECOP/WITHOUT COMPRESSOR	SECOP/WITHOUT COMPRESSOR	SECOP/WITHOUT COMPRESSOR	SECOP/WITHOUT COMPRESSOR
Evaporator Fans brand	EBM	EBM	EBM	EBM
Controller Brand	CAREL	CAREL	CAREL	CAREL
Light	LED LIGHT	LED LIGHT	LED LIGHT	LED LIGHT
40 ' Container load	18	18	8	6

SERVICE OVER COUNTER PLUG-IN&REMOTE



Features

- The appearance looks nice and elegant,the display effect is excellent
- R404a/R744 refrigerant.
- Off-cycle defrost, reduces the energy consumption.
- The product uses high efficient evaporator,it increases the heat exchange rate,the refrigeration power is large.
- There is a solenoid valve for each cabinet.We put a filter in front of the solenoid valve to reduce the difficulty and period of installation,limit the risk of dirt blockage.
- Optional high efficiency fan can be selected according to customers' requirement.
- The display effect is good,easy to get or restock products.

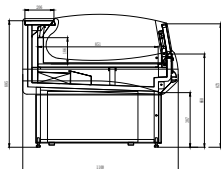

Product Model	BSM-1311RA/ CSM-1311RA	BSM-2011RA/ CSM-2011RA	BSM-2511RA/ CSM-2511RA	BSM-3811RA/ CSM-3811RA
Unit Dimension (W/D/H mm)	1350*1100*910	1980*1100*910	2600*1100*910	3850*1100*910
Packing Dimensions (W / D/ H mm)	1450*1160*1100	2100*1160*1100	2700*1160*1100	3950*1160*1100
Display Area(M2)	1.08	1.56	2.02	3.08
Effective Volume (L)	290	410	530	750
Cooling system	Ventilated	Ventilated	Ventilated	Ventilated
Temperature range	3M1	3M1	3M1	3M1
Kind of Refrigerant	R404A	R404A	R404A	R404A
Compressor brand	SECOP/WITHOUT COMPRESSOR	SECOP/WITHOUT COMPRESSOR	SECOP/WITHOUT COMPRESSOR	SECOP/WITHOUT COMPRESSOR
Evaporator Fans brand	EBM	EBM	EBM	EBM
Controller Brand	CAREL	CAREL	CAREL	CAREL
Light	LED LIGHT	LED LIGHT	LED LIGHT	LED LIGHT
40 ' Container load	32	20	16	12

STAINLESS STEEL FISH COUNTER



SMF-25L

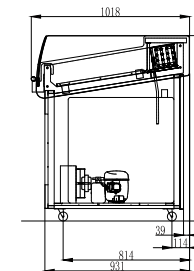

Features

- Interior and exterior stainless steel AISI304 material for high level product
- Digital thermostat Italian famous brand Dixell,Carel,Eliwell
- Adjustable feet or caster wheels
- High quality compressor:Danfoss, Embraco
- Germany Well-known brand EBM fans
- Finned evaporator
- Thermostatic expansion valve
- R404A



Product Model	SMF-25L
Unit Dimension (W/D/H mm)	2510*1018*1195
Packing Dimensions (W / D/ H mm)	2600*1140*1250
Effective Volume (L)	180
Display Area(M2)	1.80
Cooling system	Static
Temperature range	-4~0
Glass Door No.	3
Compressor brand	SECOP/EMBRACO
Kind of Refrigerant	R290/R404A
40 ' Container load	16

THE COUNTER CABINET HANGING MEAT CABINET

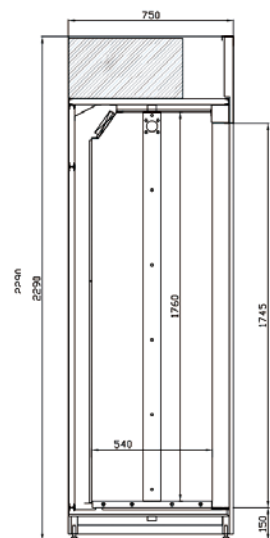

Features

- Appropriate exhibition put cold fresh meat
- Large capacity, large exhibition space
- Clised design, danfoss valves

Product Model	HMC-1975
Unit Dimension (W/D/H mm)	1880*750*2290
Packing Dimensions (W / D/ H mm)	2100*900*2400
Display Area(M ²)	1.88
Effective Volume (L)	1680
Cooling system	Ventilated
Temperature range	3M1
Kind of Refrigerant	R404A
Compressor brand	BOYANG
Evaporator Fans brand	EBM
Controller Brand	CAREL
Light	LED LIGHT
40 ' Container load	13

THE COUNTER CABINET FREEZER CABINET



Features

- Transparent design, fully display effect
- Refrigerant R404A, green pollution-free
- Refrigeration and freezing all can meet
- The whole machine, optional

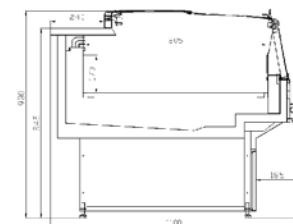

Product Model	CF-2011	CF-2611
Unit Dimension (W/D/H mm)	2000*1100*930	2620*1100*930
Packing Dimensions (W / D/ H mm)	2200*1200*1230	2800*1200*1230
Display Area(M ²)	1.62	2.18
Effective Volume (L)	410	520
Cooling system	Ventilated	Ventilated
Temperature range	3L1	3L1
Kind of Refrigerant	R404A	R404A
Compressor brand	CRSS(SANYANG)	CRSS(SANYANG)
Evaporator Fans brand	EBM	EBM
Controller Brand	CAREL	CAREL
Light	LED LIGHT	LED LIGHT
40 ' Container load	18	8

COMBINET CABINETS PLUG-IN&REMOTE

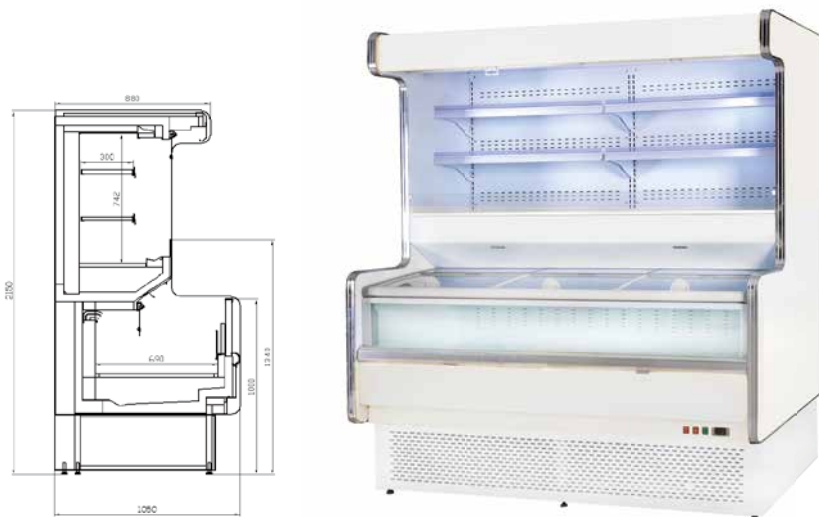

Features

- Ark of a dual temperature, the save area
- Danfoss valves, dixcell thermostat
- LED lighting, energy saving province electricity
- The machine type and split type is optional
- SCB type with compressor
- SCC type without compressor

Product Model	SBC-1911	SBC-2411	SBC-1911	SBC-2411
Unit Dimension (W/D/H mm)	1900*1050*2050	2400*1050*2050	1900*1050*2050	2400*1050*2050
Packing Dimensions (W / D/ H mm)	2100*1160*2250	2600*1160*2250	2100*1160*2250	2600*1160*2250
Display Area(M2)	4.81	6.77	4.81	6.77
Effective Volume (L)	0.72	0.97	0.72	0.97
Cooling system	Ventilated	Ventilated	Ventilated	Ventilated
Temperature range	3M1&3L1	3M1&3L1	3M1&3L1	3M1&3L1
Kind of Refrigerant	R404A	R404A	R404A	R404A
Compressor brand	CRSS(SANYANG)	CRSS(SANYANG)	WITHOUT	WITHOUT
Evaporator Fans brand	EBM	EBM	EBM	EBM
Controller Brand	CAREL	CAREL	CAREL	CAREL
Light	LED LIGHT	LED LIGHT	LED LIGHT	LED LIGHT
40' Container load	10	8	10	8

COLD STORAGE



Features

- High-grade coating heating glass door, automatic door except the dew, good display effect
- Microcomputer automatic control technology, automatic control temperature and defrosting, operation more convenient, more accurate temperature control
- High density overall pu heat preservation material, heat preservation and energy saving, durable
- Aluminum alloy frame design, easy to clean, not deformation, beautiful appearance generous
- Wind cooling refrigeration, refrigeration more even, the speed is more quickly
- Ball bearing slide design, drinks supply automatically



Product Model	3 Door	4 Door	5 Door	6 Door	7 Door	8 Door
External Dimensions (W/D/H mm)	2312*1800*2200	3083*1800*2200	3855*1800*2200	4625*1800*2200	5396*1800*2200	6166*1800*2200
Temperature (°C)	+4~+10	+4~+10	+4~+10	+4~+10	+4~+10	+4~+10

UPRIGHT ICE CREAM SHOWCASES

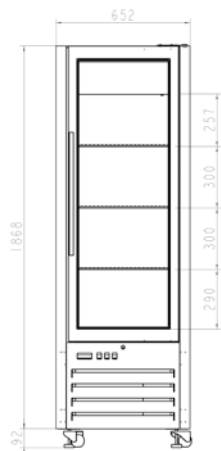

1:10



Features

- Temperature:-18~-15°C.
- Four sides toughened glass of three layers.
- Adjustable shelf.
- 4 universal wheels with adjustable feet.
- The door opens and the fan closes at once, reduce the loss of cold capacity
- Glass defrosting switch .The user can switch off the defrosting switch at night or in a dry environment, and save energy.
- Automatic defrost.
- Automatic evaporation of defrosting water.
- Micro channel condenser.
- Digital thermostat italian famous brand :dixell eliwell.
- Inside four corners with LED vertical lamp.
- Germany well-known brand EBM fans.

www.santagroup.com.cn info@santagroup.com.cn



FD-430S



FD-430R

Product Model	FD-430S	FD-430R
Unit dimensions (W / D / H mm)	650*650*1950	650*650*1950
Packing dimensions (W / D / H mm)	720*760*2212	720*760*2212
Cooling system	No Frost	No Frost m
Effective Volume(M ³)	0.4	0.4
Display Area(M ²)	2.4	2.4
Kind of coolant	R290	R290
Temperature range	-18~-15°C	-18~-15°C
Light	LED	LED
40' Container load	48	48

www.santagroup.com.cn info@santagroup.com.cn

UPRIGHT CAKE SHOWCASES

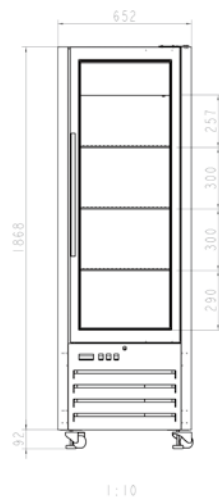

Features

- Temperature: 2~10°C.
- Four sides toughened glass .
- Adjustable shelf.
- 4 universal wheels with adjustable feet.
- The door opens and the fan closes at once, reduce the loss of cold capacity
- Glass defrosting switch .The user can switch off the defrosting switch at night or In a dry environment, and save energy.
- Automatic defrost.
- Automatic evaporation of defrosting water.
- Micro channel condenser.
- Digital thermostat italian famous brand :dixell /eliwell.
- Inside four corners with LED vertical lamp.
- Germany well-known brand EBM fans.



FC-430S



FC-430R

Product Model	FC-430S	FC-430R
Unit dimensions (W / D/ H mm)	650*650*1950	650*650*1950
Packing dimensions (W / D/ H mm)	720*760*2212	720*760*2212
Cooling system	No Frost	No Frost
Effective Volume(M ³)	0.4	0.4
Display Area(M ²)	2.4	2.4
Kind of coolant	R290	R290
Temperature range	2~8°C	2~8°C
Light	LED	LED
40 ' Container load	48	48

CAKE SHOWCASES



FC500RA



FC500SA

Features

- Temperature: 2~8°C
- toughened glass
- Adjustable shelf.
- Automatic defrost.
- Automatic evaporation of defrosting water.
- Digital thermostat
- InsideLED lamp



Product Model	FC-400RA/SA	FC-500RA/SA	FC-600RA/SA	FC-700RA/SA
Unit dimensions (W / D/ H mm)	900*660*1200	1200*660*1200	1500*660*1200	1800*660*1200
Packing dimensions(W / D/ H mm)	1000*760*1300	1300*760*1300	1600*760*1300	1900*760*1300
Cooling system	No Fros	No Frost	No Frost	No Frost
Climate class	4	4	4	4
Effective Volume(L)	340/360	450/480	560/595	680/724
Display Area(M ²)	0.78/0.79	0.98/1	1.27/1.3	1.54/1.58
Kind of coolant	R134a	R134a	R134a	R134a
Temperature range	2~8°C	2~8°C	2~8°C	2~8°C
Shelves	2	2	2	2
Light	LED	LED	LED	LED
Digital thermostat	KAIDE	KAIDE	KAIDE	KAIDE
40 ' Container load	70	54	44	24

ECONOMIC CAKE SHOWCASES



RC500RB



FC500SB

Features

- Temperature: 2~8°C.
- toughened glass .
- Adjustable shelf.
- Automatic defrost.
- Automatic evaporation of defrosting water.
- Digital thermostat
- InsideLED lamp



Product Model	FC-400RB/SB	FC-500RB/SB	FC-600RB/SB	FC-700RA/SB
Unit dimensions (W / D/ H mm)	900*660*1200	1200*660*1200	1500*660*1200	1800*660*1200
Packing dimensions(W / D/ H mm)	1000*760*1300	1300*760*1300	1600*760*1300	1900*760*1300
Cooling system	No Frost	No Frost	No Frost	No Frost
Climate class	4	4	4	4
Effective Volume(L)	340/360	450/480	560/595	680/714
Display Area(M ²)	0.78/0.79	0.98/1	1.27/1.3	1.54/1.58
Kind of coolant	R134a	R134a	R134a	R134a
Temperature range	2~8°C	2~8°C	2~8°C	2~8°C
Shelves	2	2	2	2
Light	LED	LED	LED	LED
Digital thermostat	KAIDE	KAIDE	KAIDE	KAIDE
40 ' Container load	70	54	44	24

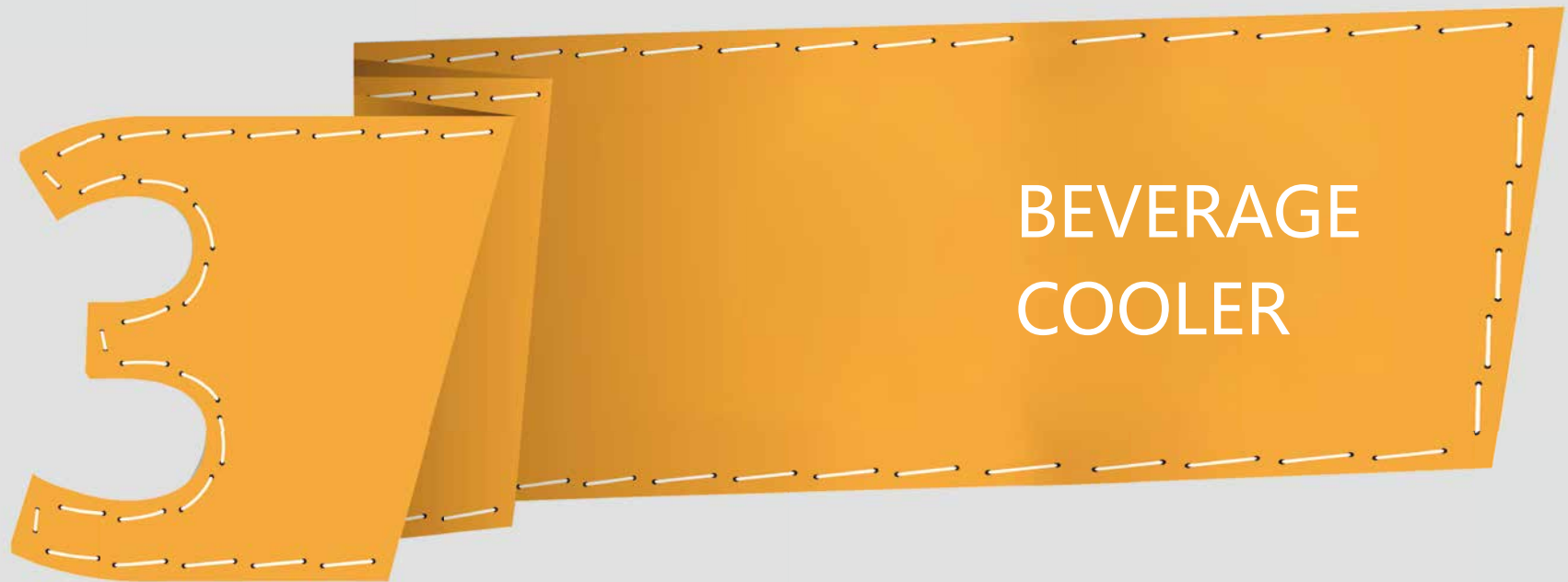

BEVERAGE
COOLER

BACKBAR FAN COOLING WITH HINGED DOOR



BBS-130

BBD-230

BBT-350

Features

- Automatic self-closing door
- Double layers tempered glass
- Fan assisted cooling
- Removable digital thermostat
- Interior LED light
- 2 adjustable shelves per door
- Exterior material: Black pre-coated steel, Interior material embossed aluminium

Options

- Horizontal or vertical handle
- Inner box white prepainted steel
- Sliding door, for two door and three door model
- Door frame and body Stainless steel material

Product Model	BSS-130L	BBD-230L	BBT-350L
Unit Dimensions (W/D/H mm)	600*520*900	900*520*900	1350*520*900
Door Type	Hinged	Hinged	Hinged
Material	Ext. prepainted steel, Int.embossed AL	Ext. prepainted steel, Int.embossed AL	Ext. prepainted steel, Int.embossed AL
Net capacity (L)	138	208	320
Cooling system	Fan cooling	Fan cooling	Fan cooling
Temperature (°C)	0~+8	0~+8	0~+8
Shelves No.	2	4	6
Interior light	LED Light	LED Light	LED Light
Compressor	Zanussi	Zanussi	Zanussi
Digital thermostat	Dixell	Dixell	Dixell
Kind of coolant	R134a/R600a	R134a/R600a	R134a/R600a
40' Container loading	144	96	66

BACKBAR FAN COOLING WITH SLIDING DOOR



BBD-230S

BBT-350S

Features

- Automatic self-closing door
- Double layers tempered glass
- Fan assisted cooling
- Removable digital thermostat
- Interior LED light
- 2 adjustable shelves per door
- Exterior material: Black pre-coated steel, Interior material embossed aluminium

Options

- Inner box white prepainted steel



Product Model	BBD-230S	BBT-350S
Unit Dimensions (W/D/H mm)	900*520*900	1350*520*900
Door Type	Sliding	Sliding
Material	Ext. prepainted steel, Int.embossed AL	Ext. prepainted steel, Int.embossed AL
Net capacity (L)	208	320
Cooling system	Fan cooling	Fan cooling
Temperature (°C)	0~+8	0~+8
Shelves No.	4	6
Interior light	LED Light	LED Light
Compressor	Zanussi	Zanussi
Digital thermostat	Dixell	Dixell
Kind of coolant	R134a/R600a	R134a/R600a
40' Container loading	96	66

BACKBAR

FAN COOLING WITH STAINLESS STEEL BODY



BBS-130LS



BBD-230LS

Features

- Automatic self-closing door
- Double layers tempered glass
- Fan assisted cooling
- Removable digital thermostat
- Interior LED light
- 2 adjustable shelves per door
- Exterior material : Stainless steel, Interior material embossed aluminium

Options

- Horizontal or vertical handle
- Inner box white prepainted steel

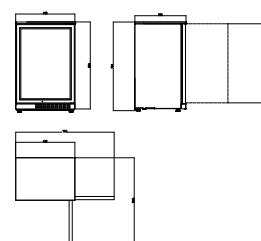

BBS-130L&BBS-130LS

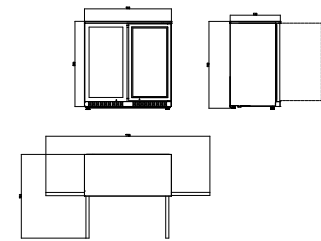

BBD-230L&BBD-230S&BBD-230LS

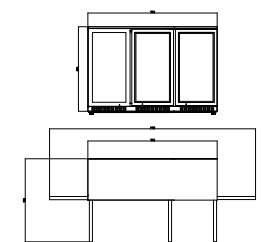

BBT-350L&BBT-350S&BBT-350LS

Product Model	BBS-130LS	BBD-230LS	BBT-350LS
Unit Dimensions (W/D/H mm)	600*520*900	900*520*900	1350*520*900
Door Type	Hinged	Hinged	Hinged
Material	Ext. SS, Int.embossed AL	Ext. SS, Int.embossed AL	Ext. SS, Int.embossed AL
Net capacity (L)	138	208	320
Cooling system	Fan cooling	Fan cooling	Fan cooling
Temperature (°C)	0~+8	0~+8	0~+8
Shelves No.	2	4	6
Interior light	LED Light	LED Light	LED Light
Compressor	Zanussi	Zanussi	Zanussi
Digital thermostat	Dixell/Elitech	Dixell/Elitech	Dixell/Elitech
Kind of coolant	R134a/R600a	R134a/R600a	R134a/R600a
40' Container loading	144	100	66

BEVERAGE COOLER DIRECT COOLING



SC-110U



SC-60U

Features

- One glass door upright chiller
- Ext. white prepainted sheet, int.white PS
- Int. roll bond plate for cooling
- Three layers of shelves
- Foaming agent:C-P
- With wheels
- R134a, 230V 50HZ

Options

- R600a, 115V 60HZ
- Inner box black or white

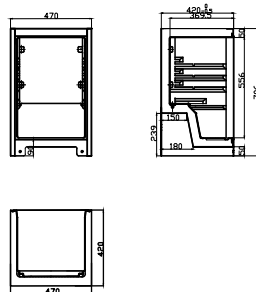

SC-60U&SC-110U



Product Model	SC-60U	SC-110U
Unit Dimension (W/D/H mm)	475*517*746	475*517*1017
Packing Dimensions (W/D/H mm)	515*555*790	515*555*1060
Net capacity (L)	60	100
Cooling system	Static	Static
Foaming thickness(mm)	45	45
Climate	N/ST	N/ST
Temperature (°C)	0~10	0~10
Shelves No.	3	3
Kind of coolant	R134a/R600a	R134a/R600a
40 'HC Container loading	272	184

BEVERAGE COOLER DIRECT COOLING



SC-110



SC-60

Features

- One glass door upright chiller
- Ext. white prepainted sheet, int.white PS
- Int. roll bond plate for cooling
- Three layers of shelves
- Foaming agent:C-P
- With wheels
- R134a, 230V 50HZ

Options

- R600a, 115V 60HZ

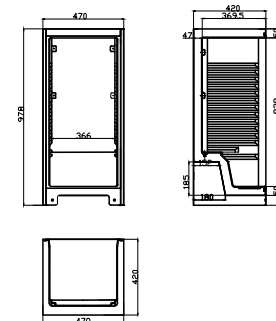

SC-110&SC-60



Product Model	SC-60	SC-110
Unit Dimension (W/D/H mm)	475*517*746	475*517*1017
Packing Dimensions (W/D/H mm)	515*555*790	515*555*1060
Net capacity (L)	60	100
Cooling system	Static	Static
Foaming thickness(mm)	45	45
Climate	N/ST	N/ST
Temperature (°C)	0~10	0~10
Shelves No.	3	3
Kind of coolant	R134a/R600a	R134a/R600a
40 'HC Container loading	272	184

BEVERAGE COOLER DIRECT COOLING

CECB



SD-70 with canopy



SD-120

Features

- Horizontal LED illumination on top
- Aluminum foot frame
- Adjustable temperature controller
- 3 Layer durable PVC coated shelves
- Triple layer tempered glass door with electrical heating
- Wire and tube condenser with fan assistant
- Self-Closing door
- Adjustable feet

Options

- Lockable door
- Digital controller
- Sticker on side of cabinet
- With canopy +200mm height



Product Model	SD-70	SD-120
Unit Dimensions (W/D/H mm)	595*555*585	595*555*785
Packing Dimensions (W/D/H mm)	620*583*630	620*583*850
Net capacity(L)	65	112
Cooling system	Static	Static
Foaming thickness(mm)	45	45
Climate	N/ST	N/ST
Temperature (°C)	≤-18	≤-18
Shelf NO.	1	2
Kind of coolant	R134a/R600a	R134a/R600a
Led light	On the top	On the top
40HC' container load	304	228

BEVERAGE COOLER DIRECT COOLING

CECB



SC-320

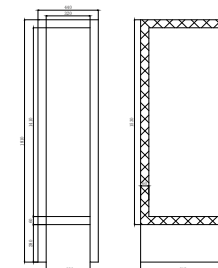

Features

- One glass door upright slim cooler
- Outside PCM, inside white preprinted aluminium sheet
- Fan assisted cooling
- Interior vertical LED light
- Adjustable shelves
- Aluminium door frame
- Self-closing door
- Double layer glass, outside tempered
- Front two wheels, Rear two feet

Product Model	SC-320
Unit Dimensions (W/D/H mm)	440*718*1850
Packing Dimensions (W/D/H mm)	478*775*1990
Climate class	4
Gross capacity	311
Cooling system	rollbon
Defrost	automatic
Compresspr	ZEL
Kind of coolant	R600a
Temperature range	2~8°C
Inner light	vertical LED lamp
Thermostat	mechanical
Shelf (wire ,white)	5 pcs
40HC' container load	75

BEVERAGE COOLER

DIRECT COOLING

CE CB



SC-278

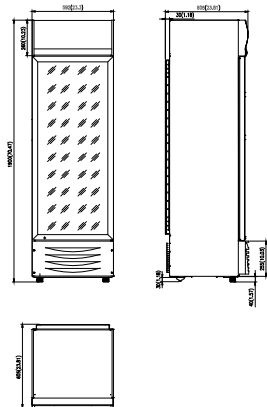

SC-278

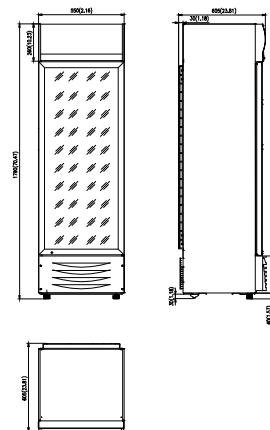

SC-238

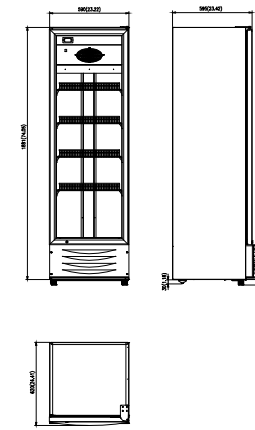

SC-350

Features

- One glass door upright beverage cooler
- Outside White PCM, inside white prepainted aluminium sheet
- Fan assisted cooling
- Interior light
- Adjustable shelves
- White plastic door frame
- Lock and key
- Front two wheels, Rear two feet
- 230V 50HZ

Options

- Door frame color black or any other color
- Digital thermostat
- Two side painting
- With Canopy



Product Model	SC-238	SC-278	SC-350
Unit Dimensions (W/D/H mm)	550*575*1780	590*575*1905	590*645*1905
Packing Dimensions (W/D/H mm)	640*630*1835	665*630*1970	675*660*1975
Climate Class	ST	ST	ST
Net capacity (L)	238	278	320
Cooling system	Static with fan assisted cooling	Static with fan assisted cooling	Static with fan assisted cooling
Interior light	Top*1	Top*1	Vertical LED *1
Canopy	Yes	Yes	Option
Temperature (°C)	0~+10	0~+10	0~+10
Shelves No.	3	4	4
Compressor	LG	LG	LG
Thermostat	Mechanical/Digital	Mechanical/Digital	Mechanical/Digital
Kind of coolant	R134a/R600a	R134a/R600a	R134a/R600a
Door Type	Hinged	Hinged	Hinged
40' Container loading	54	54	54

BEVERAGE COOLER

DIRECT COOLING

CE CB



SC-708

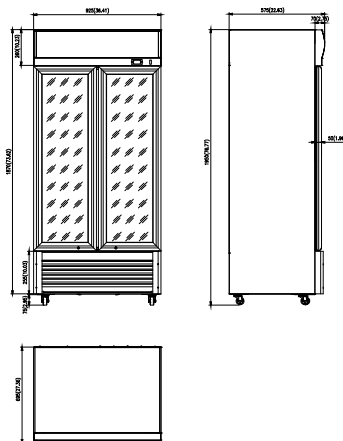

SC-708

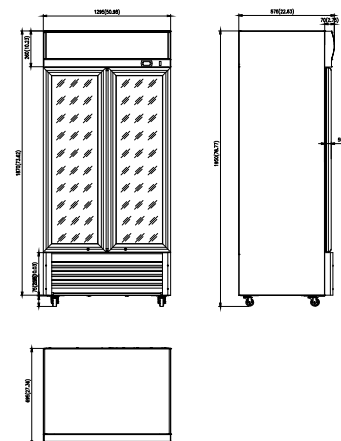

SC-508

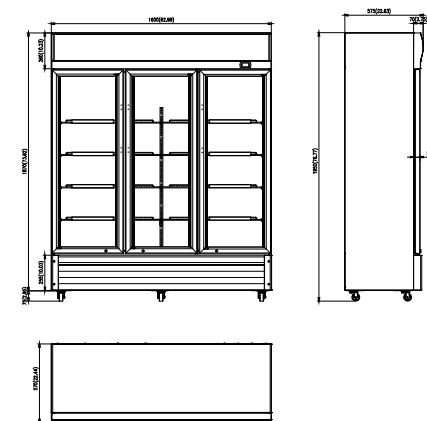

SC-1008

Features

- Two glass door no frost upright beverage cooler
- Outside White PCM, inside white prepainted aluminium sheet
- No frost type
- Automatic defrost system
- Air blow up from bottom grill
- Interior Vertical light
- Adjustable shelves
- Black plastic door frame
- Double layer glass, outside tempered
- Bottom wire tube and fan assisted condensing
- Lock and key
- Four caster wheels
- 230V 50HZ

Options

- Any other color door frame
- Digital thermostat
- Two side painting
- With Canopy



Product Model	SC-508	SC-708	SC-1008
Unit Dimensions (W/D/H mm)	925*570*1945	1295*570*1945	1600*570*1945
Packing Dimensions (W/D/H mm)	1010*640*2020	1380*640*2020	1685*640*2020
Climate Class	ST	ST	ST
Net capacity (L)	508	708	900
Cooling system	Static with fan assisted cooling	Static with fan assisted cooling	Static with fan assisted cooling
Interior light	Vertical LED *2	Vertical LED *2	Vertical LED *2
Canopy	Yes	Yes	Yes
Temperature (°C)	0~+10	0~+10	0~+10
Shelves No.	8	8	12
Compressor	LG	LG	LG
Thermostat	Mechanical/Digital	Mechanical/Digital	Mechanical/Digital
Kind of coolant	R134a/R600a	R134a/R600a	R134a/R290
Door Type	Hinged	Hinged	Hinged
40' Container loading	36	26	21

BEVERAGE COOLER

VENTIALED COOLING

CE



SC-278F

Features

- One glass door upright beverage cooler
- Outside White PCM, inside white prepainted aluminium sheet
- Fan assisted cooling
- Interior light
- Adjustable shelves
- White plastic door frame
- With Canopy
- Lock and key
- Front two wheels, Rear two feet
- 230V 50HZ

Options

- Door frame color black or any other color
- Digital thermostat
- Two side painting

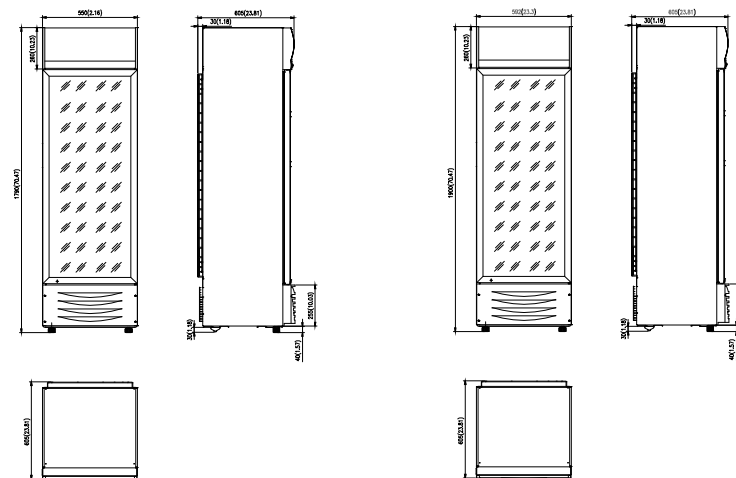

SC-238

SC-278

Product Model	SC-238F	SC-278F
Unit Dimensions (W/D/H mm)	550*605*1780	592*605*1900
Packing Dimensions (W/D/H mm)	645*630*1835	675*630*1970
Climate Class	ST	ST
Net capacity (L)	238	278
Cooling system	Ventilated	Ventilated
Interior light	Top*1	Top*1
Canopy	Yes	Yes
Temperature (°C)	0~+10	0~+10
Shelves No.	4	4
Compressor	ZEL	ZEL
Thermostat	Mechanical/Digital	Mechanical/Digital
Kind of coolant	R134a	R134a
Door Type	Hinged	Hinged
40' Container loading	54/73	54/72

BEVERAGE COOLER

VENTILATED COOLING



SC-350F



SC-350

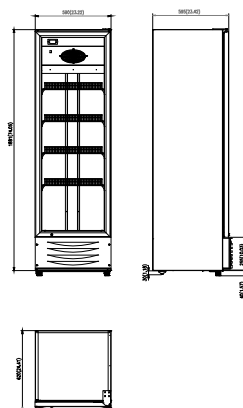

SC-350

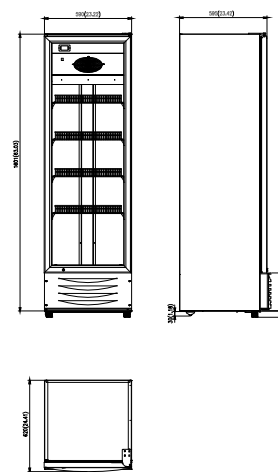

SC-280

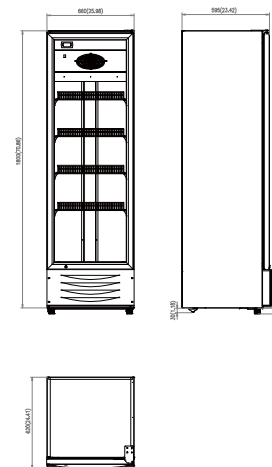

SC-420

Features

- One glass door no frost upright beverage cooler
- Outside White PCM, inside white prepainted aluminium sheet
- No frost type
- Automatic defrost system
- Air blow up from bottom grill
- Interior Vertical light
- Adjustable shelves
- Black plastic door frame
- Double layer glass, outside tempered
- Bottom wire tube and fan assisted condensing
- Lock and key
- Front two wheels, Rear two feet
- 230V 50HZ

Options

- Any other color door frame
- Digital thermostat
- Two side painting
- With Canopy



Product Model	SC-280F	SC-350F	SC-420F
Unit Dimensions (W/D/H mm)	590*635*1635	590*635*1915	660*665*1875
Packing Dimensions (W/D/H mm)	675*660*1700	675*660*1975	735*720*1940
Climate Class	ST	ST	ST
Net capacity (L)	260	330	420
Cooling system	Ventilated	No Frost	No Frost
Interior light	Vertical LED *1	Vertical LED *1	Vertical LED *1
Canopy	Option	Option	Option
Temperature (°C)	0~+10	0~+10	0~+10
Shelves No.	4	4	4
Thermostat	Mechanical/Digital	Mechanical/Digital	Mechanical/Digital
Kind of coolant	R134a	R134a	R134a
Door Type	Hinged	Hinged	Hinged
40' Container loading	54/73	54	48

BEVERAGE COOLER

VENTILATED COOLING



CE



SC-630FH



SC-960

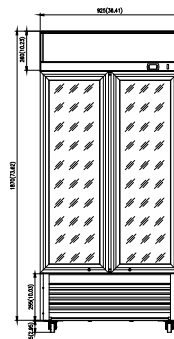

SC-630

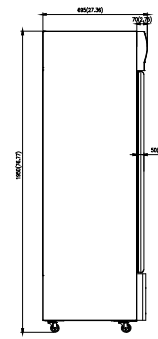

SC-908

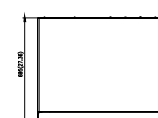
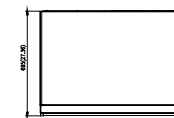

Features

- Two glass door no frost upright beverage cooler
- With Hinged door
- Outside White PCM, inside white preprinted aluminium sheet
- No frost type
- Automatic defrost system
- Interior two side Vertical light
- Adjustable shelves
- Black plastic door frame
- Double layer glass, outside tempered
- Digital thermostat
- Lock and key
- Four caster wheels
- 230V 50HZ

Options

- White color or aluminium door frame
- Two side painting
- Sliding door



Product Model	SC-630FH	SC-630FS	SC-908F	SC-908FS
Unit Dimensions (W/D/H mm)	925*695*1990	925*695*1990	1295*695*1990	1295*695*1990
Packing Dimensions (W/D/H mm)	1000*760*2070	1000*760*2070	1370*760*2070	1370*760*2070
Climate Class	ST/N	ST/N	ST/N	ST/N
Net capacity (L)	630	630	880	880
Cooling system	Ventilated	Ventilated	Ventilated	Ventilated
Interior light	Vertical LED *2	Vertical LED *2	Vertical LED *2	Vertical LED *2
Canopy	Yes	Yes	Yes	Yes
Temperature (°C)	0~+10	0~+10	0~+10	0~+10
Shelves No.	8	8	8	8
Thermostat	Mechanical/Digital	Mechanical/Digital	Mechanical/Digital	Mechanical/Digital
Kind of coolant	R134a/R290	R134a/R290	R134a/R290	R134a/R290
Door Type	Hinged	Sliding	Hinged	Sliding
40' Container loading	33	33	25	25

BEVERAGE COOLER VENTILATED COOLING



SC-1030FA



SC-1030FB

Features

- Double tempered glass door with Low-E film
- With hinged door
- Precoating sheet alumin,white
- Copper-aluminium fin evaporator+Fan
- No frost type
- Automatic defrost system
- Adjustable shelves
- Lock and key
- Interior two side vertical light
- 10 Adjustable shelves



Options

- Carton box
- Two side painting

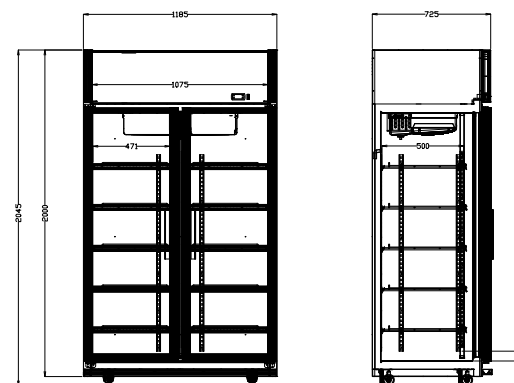

SC-1030

Product Model	SC-1030FA	SC-1030FB
Unit Dimensions (W/D/H mm)	1185*730*2000	1185*730*2000
Packing Dimensions (W/D/H mm)	1250*780*2100	1250*780*2100
Cooling system	No Frost	No Frost
Type of appliance	Free standing	Free standing
Climate Class	ST	ST
Net capacity (L)	880	880
Kind of coolant	R134a	R134a
Interior light	Vertical LED *2	Vertical LED *2
Temperature (°C)	0~+10	0~+10
Digital thermostat	Dixell	Dixell
Shelves No.	10	10
Compressor	Embraco	Embraco
40° Container loading	27	27

MERCHANDISER-COOLER



ST-23RGD



ST-72RGD

Features

- Aluminum door frame
- Three layer glass, outside tempered with electrical heating
- Interior two side vertical light
- Automatic defrost system
- Copper-aluminium fin evaporator+Fan
- Lock and key
- No frost type

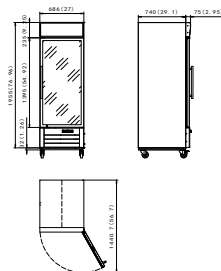

Product Model	ST-23RGD	ST-49RGD	ST-72RGD
Unit Dimensions (W/D/H mm)	686*850*2117	1375*850*2117	2062*850*2117
Packing Dimensions (W/D/H mm)	766*900*2160	1410*900*2160	2117*900*2160
Cooling system	No Frost	No Frost	No Frost
Door Type	Hinged	Hinged	Hinged
Climate Class	ST	ST	ST
Net capacity (L)	650	1280	1945
Kind of coolant	R404a	R404a	R404a
Interior light	Vertical LED *1	Vertical LED *2	Vertical LED *1
Temperature (°C)	0~7	0~7	0~7
Digital thermostat	Dixell	Dixell	Dixell
Shelves No.	3	6	9
Compressor	Embraco	Embraco	Embraco
40' Container loading	39	21	13

MERCHANDISER-FREEZER



ST-23FGD



ST-49FGD

Features

- Aluminum door frame
- Three layer glass, outside tempered with electrical heating
- Interior two side vertical light
- Automatic defrost system
- Copper-aluminium fin evaporator+Fan
- Lock and key
- No frost type

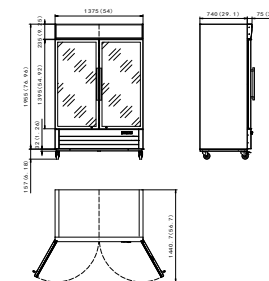

Product Model	ST-23FGD	ST-49FGD	ST-72FGD
Unit Dimensions (W/D/H mm)	686*850*2117	1375*850*2117	2062*850*2117
Packing Dimensions (W/D/H mm)	766*900*2160	1410*900*2160	2117*900*2160
Cooling system	No Frost	No Frost	No Frost
Door Type	Hinged	Hinged	Hinged
Climate Class	ST	ST	ST
Net capacity (L)	650	1280	1945
Kind of coolant	R404a	R404a	R404a
Interior light	Vertical LED *1	Vertical LED *2	Vertical LED *2
Temperature (°C)	-18~-22	-18~-22	-18~-22
Digital thermostat	Dixell	Dixell	Dixell
Shelves No.	3	6	9
Compressor	Embraco	Embraco	Embraco
40' Container loading	39	21	13



CHEST
FREEZER

TOP CURVED SLIDING GLASS LID



SD-320Q



SD-620Q

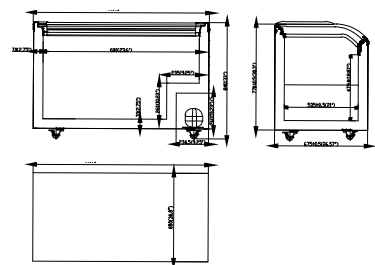

SD-220Q

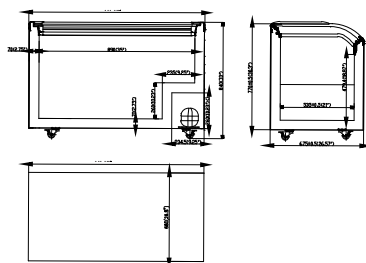

SD-320Q

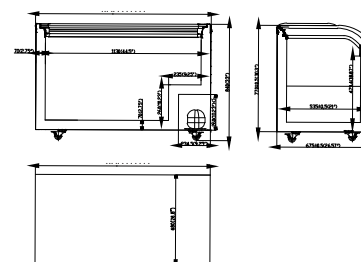

SD-420Q

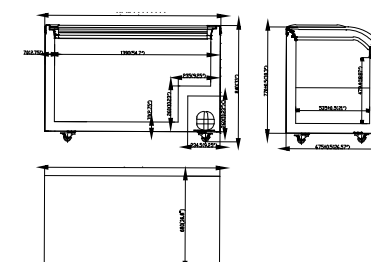

SD-520Q

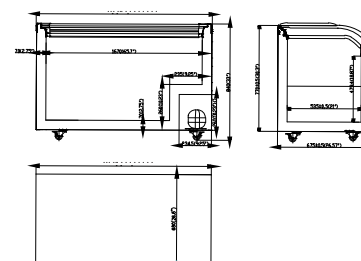

SD-620Q

Features

- New style curved sliding glass lid
- Fully Automatic operation
- 70 mm thickness insulation
- Exterior white finish
- Aluminum door frame
- Adjustable thermostat
- Main power indicator
- Defrost water drain hole
- Full basket as standard
- Interior LED light as standard
- Four caster wheels
- Environmentally friendly

Options

- Digital thermometer



Product Model	SD-220Q	SD-320Q	SD-420Q	SD-520Q	SD-620Q
Unit Dimensions (W/D/H mm)	740*680*850	1030*680*850	1270*680*850	1530*680*850	1810*680*850
Packing Dimension (W/D/H mm)	790*780*890	1080*780*890	1320*780*890	1580*780*890	1860*780*890
Net capacity (L)	180	273	355	445	545
Cooling system	Static	Static	Static	Static	Static
Climate	N/ST	N/ST	N/ST	N/ST	N/ST
Temperature (°C)	≤-18	≤-18	≤-18	≤-18	≤-18
Number of basket	2	3	4	5	6
Controller	Mechanical	Mechanical	Mechanical	Mechanical	Mechanical
Interior light	LED	LED	LED	LED	LED
Castor	With	With	With	With	With
Kind of coolant	R134a/R290	R134a/R290	R134a/R290	R134a/R290	R134a/R290
40'HC Container loading	134	97	79	65	56

TOP FLAT GLASS LID SERIES



SD-220P

Features

- New style flat sliding glass lid
- Fully Automatic operation
- 75 mm thickness insulation
- Exterior white finish
- Aluminum door frame
- Adjustable thermostat
- Main power indicator
- Defrost water drain hole
- Full basket as standard
- Interior LED light as standard
- Four castor wheels
- Environmentally friendly

**Options**

- Digital thermometer

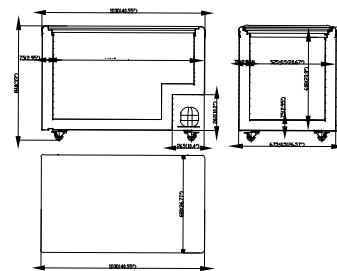

SD-320P

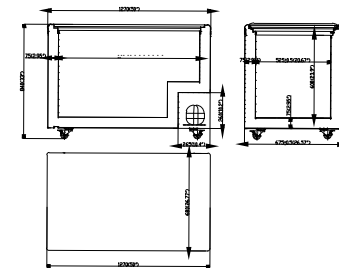

SD-420P

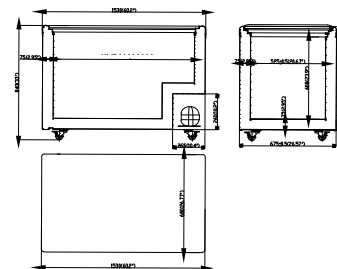

SD-520P

Product Model	SD-320P	SD-420P	SD-520P
Unit Dimensions (W/D/H mm)	1030*680*850	1270*680*850	1530*680*850
Packing Dimension (W/D/H mm)	1080*780*890	1320*780*890	1580*780*890
Net capacity (L)	273	355	445
Cooling system	Static	Static	Static
Climate	N/ST	N/ST	N/ST
Temperature (°C)	≤-18	≤-18	≤-18
Number of basket	3	4	5
Controller	Mechanical	Mechanical	Mechanical
Interior light	LED	LED	LED
Castor	With	With	With
Kind of coolant	R134a/R290	R134a/R290	R134a/R290
40'HC Container loading	97	79	65

TOP CURVED SLIDING GLASS LID

Features

- New style curved sliding glass lid
- Fully Automatic operation
- 70 mm thickness insulation
- Exterior white finish
- Aluminum door frame
- Adjustable thermostat
- Main power indicator
- Defrost water drain hole
- Full basket as standard
- Interior LED light as standard
- Four caster wheels
- Digital thermometer
- Environmentally friendly



SD-420QIC

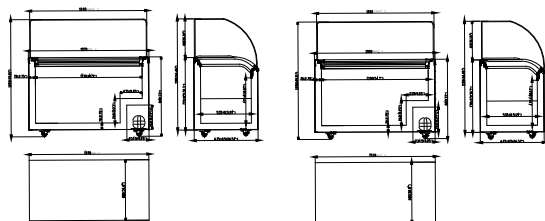

SD-420QIC

SD-520QIC

Product Model	SD-420QIC	SD-520QIC
Unit Dimensions (W/D/H mm)	1270*680*850	1530*680*850
Packing Dimension(W/D/H mm)	1320*780*890	1580*780*890
Net capacity (L)	355	445
Cooling system	Static	Static
Climate	N/ST	N/ST
Temperature (°C)	≤-18	≤-18
Number of basket	4	5
Controller Mechanical	Mechanical	Mechanical
Interior light	LED	LED
Castor	With	With
Kind of coolant	R134a/R290	R134a/R290
40'HC Container loading	79	65

TOP CURVED SLIDING GLASS LID

Features

- Top curved sliding glass lid
- Blue door frame
- 70mm thickness insulation
- suitable for wide climate, SN/T
- Adjustable thermostat
- Main power indicator
- Defrost water drain hole
- External handle with lock
- Caster wheels
- Environmentally friendly

Options

- Outside Condensor/ digital thermometer



SD-338with light box



SD-338 WITH STICKER

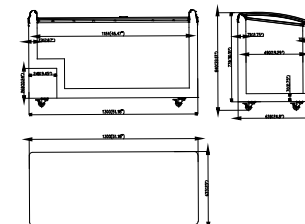

Product Model	SD-338
Unit Dimensions (W/D/H mm)	1305*635*850
Packing Dimension (W/D/H mm)	1365*745*890
Net capacity (L)	338
Cooling system	Static
Foaming thickness(mm)	70
Climate	N/ST
Temperature (°C)	-15~-25
Baskets No.	4
Kind of coolant	R134a/R290
40'HC Container loading	75

TOP FLAT GLASS LID SERIES



SD-100

SD-200

Features

- Easily open from Front or back side
- 70 mm thickness insulation
- Adjustable thermostat
- Main power indicator
- Defrost water drain hole
- Sandblasting oxidation surface treatment PVC frame
- Three-dimensional electronic thermostat, accurate temperature control, highlighting the generosity
- Adjustable feet
- Environmentally friendly

Options

- Wheels/ full baskets/digital thermometer

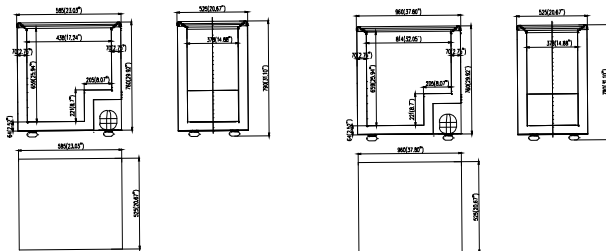

SD-100

SD-200

Product Model	SD-100	SD-200
Unit Dimensions (W/D/H mm)	585*525*840	960*525*840
Packing Dimension (W/D/H mm)	620*585*880	1000*585*880
Net capacity (L)	97	197
Cooling system	Static	Static
Climate	ST	ST
Temperature (°C)	≤-18	≤-18
Basket No.	1	1
Kind of coolant	R134a	R134a
40' Container loading	223	135

DOUBLE LAYER LID SERIES
FOAMING DOOR + INSIDE GLASS DOOR

BD-500G

Features

- Outside white foaming lid, inside sliding glass lid
- 65mm thickness insulation
- Suitable for wide climate, SN/T
- Adjustable thermostat
- Main power indicator
- Defrost water drain hole
- Handle with lock
- Adjustable feet
- Environmentally friendly

Options

- Interior LED light/wheels/outside condensor/ full baskets/digital thermometer/top SS lid



Product Model	BD-300G	BD-400G	BD-500G	BD-600G
Unit Dimensions (W/D/H mm)	1052*715*855	1322*715*855	1612*715*855	1851*715*855
Packing Dimension (W/D/H mm)	1100*760*885	1370*760*885	1660*760*885	1900*760*885
Net capacity (L)	282	376	476	540
Cooling system	Static	Static	Static	Static
Climate	ST	ST	ST	ST
Temperature (°C)	≤-18	≤-18	≤-18	≤-18
Basket No.	1	1	2	2
Kind of coolant	R134a/R600a	R134a/R600a	R134a/R600a	R134a/R600a
40'HC Container loading	96	75	63	54

CHEST FREEZER



BD-105

Features

- European super low energy consumption A+
- 70mm thickness insulation
- Suitable for wide climate, SN/T
- Adjustable thermostat
- Main power indicator
- Defrost water drain hole
- Recess handle on front side
- Adjustable feet
- Environmentally friendly
- Available in white or silver body color



Options

- Interior LED light/outside Condensor/wheels/ full baskets/digital thermometer/top SS lid

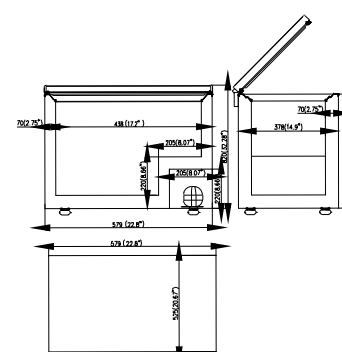

BD-105

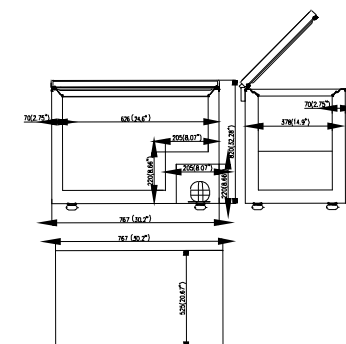

BD-155

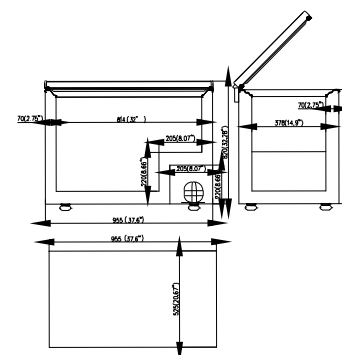

BD-205

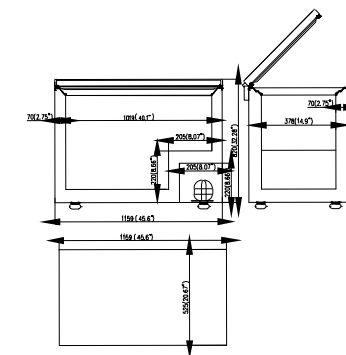

BD-255

Product Model	BD-105	BD-155	BD-205	BD-255
Unit Dimension (W/D/H mm)	580*560*840	771*560*840	960*560*840	1164*560*840
Packing Dimension (W/D/H mm)	625*585*880	815*585*880	1005*585*880	1210*585*880
Net capacity (L)	97	148	197	247
Cooling system	Static	Static	Static	Static
Foaming thickness (mm)	70	70	70	70
Climate	SN/T	SN/T	SN/T	SN/T
Energy class	A+	A+	A+	A+
Temperature (°C)	≤-18	≤-18	≤-18	≤-18
Basket No.	1	1	1	1
Kind of coolant	R600a	R600a	R600a	R600a
40 'HC Container loading	223	168	138	109

CHEST FREEZER



BD-550A



BD-550SS



Features

- European super low energy consumption A+
- 75mm thickness insulation
- Suitable for wide climate, SN/T
- Adjustable thermostat
- Main power indicator
- Defrost water drain hole
- External handle with lock
- Adjustable feet
- Environmentally friendly
- Available in white or silver body color

Options

- Interior LED light/outside Condensor/ Caster wheels/ full baskets/digital thermometer/top SS lid

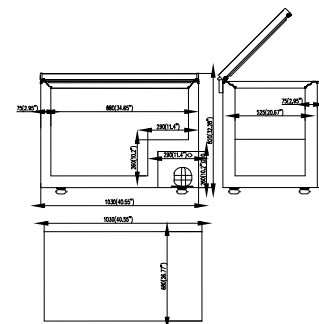

BD-350

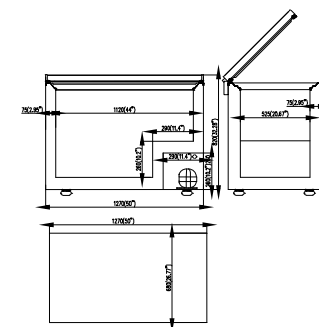

BD-450

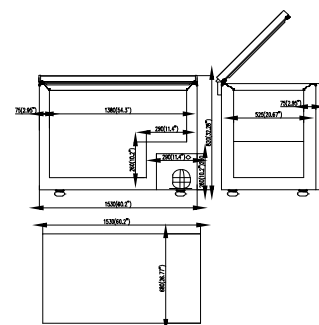

BD-550

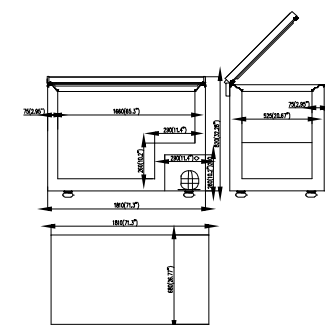

BD-650

Product Model	BD-350	BD-450	BD-550	BD-650
Unit Dimension (W/D/H mm)	1030*755*840	1270*755*840	1530*755*840	1810*755*840
Packing Dimension (W/D/H mm)	1080*780*890	1320*780*890	1580*780*890	1860*780*890
Net capacity (L)	272	358	450	550
Cooling system	Static	Static	Static	Static
Foaming thickness (mm)	75	75	75	75
Climate	SN/T	SN/T	SN/T	SN/T
Energy class	A+	A+	A+	A+
Temperature (°C)	≤-18	≤-18	≤-18	≤-18
Basket No.	1	1	2	2
Kind of coolant	R600a	R600a	R600a	R600a
40 'HC Container loading	96	79	65	56

SUPERSIZE SERIES

Features

- Supersize Chest freezer
- 80 mm thickness insulation
- Two lids as standard
- Adjustable thermostat
- Main power indicator
- Defrost water drain hole
- External handle with lock
- Two baskets inside
- Adjustable feet
- Environmentally friendly

Options

- Interior LED light/outside Condensor/ Caster wheels/full baskets/digital thermometer/top SS lid



BD-900D

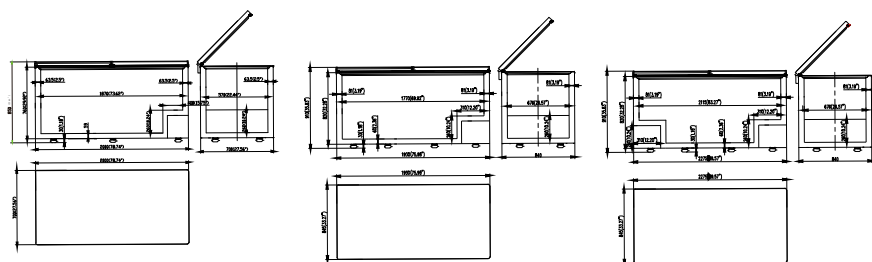

BD-700D

BD-900D

BD-1000D

Product Model	BD-700D	BD-900D	BD-1000D
Unit dimension (W/D/H mm)	2000*740*850	1930*895*910	2280*895*910
Packing dimension (W/D/H mm)	2040*770*885	1985*960*1020	2320*960*1020
Net capacity (L)	670	850	945
Cooling system	Static	Static	Static
Foaming thickness(mm)	65	80	80
Climate	ST	ST	ST
Temperature (°C)	-18	≤-18	≤-18
Basket No.	2	2	2
Kind of coolant	R134a/R290	R134a/R600a	R134a/R600a
40 'HC Container loading	51	24	24

DUAL TEMPERATURE SERIES



BCD-216

Features

- Two separate cooling and freezing chambers to keep food fresh
- 70 mm thickness insulation
- Two lids as standard
- Adjustable thermostat
- Main power indicator
- Defrost water drain hole
- External handle with lock
- Super silent performance
- Adjustable feet
- Environmentally friendly

Options

- Interior LED light/outside Condensor/ Caster wheels/ full baskets/digital thermometer/top SS lid



Product Model	BCD-166	BCD-196	BCD-216	BCD-266
Unit dimension (W/D/H mm)	841*630*815	964*630*815	964*630*865	1184*630*865
Packing dimension (W/D/H mm)	885*655*840	1005*655*840	1005*655*890	1225*655*890
Net capacity (L)	96/57	118/62	129/71	160/90
Cooling system	Static	Static	Static	Static
Climate	ST	ST	ST	ST
Temperature (°C)	Freezer:-15~-25; Ref : -2~10	Freezer : -15~-25; Ref : -2~10	Freezer : -15~-25; Ref : -2~10	Freezer : -15~-25; Ref : -2~10
Kind of coolant	R134a/R600a	R134a/R600a	R134a/R600a	R134a/R600a
40'HC Container loading	132	123	123	84

THREE TEMPERATURE ZONE



BCD-218

Features

- Three independent room
- Combined chiller&freezer, middle room soft freezing
- 65mm thickness insulation
- suitable for wide climate, SN/T
- Adjustable thermostat
- Main power indicator
- Defrost water drain hole
- External handle with lock
- Adjustable feet
- Environmentally friendly



Options

- Outside Condensor/ Caster wheels/ full baskets/digital thermometer/top SS lid

Product Model	BCD-218	BCD-248
Unit dimension (W/D/H mm)	1184*620*825	1184*620*885
Packing dimension (W/D/H mm)	1240*650*870	1240*650*930
Net capacity (L)	218	248
Cooling system	Static	Static
Foaming thickness (mm)	65	65
Climate	N/ST	N/ST
Temperature (°C)	Cooler: 0~10, Freezer: ≤ -18	Cooler: 0~10, Freezer: ≤ -18
Baskets No.	1	1
Kind of coolant	R134a/R600a	R134a/R600a
40'HC Container loading	84	77

BUTTERFLY LID FLAT BOTTOM



BD/BC-200

Features

- Switchable temperature for freezing and cooling
- Top butterfly lids
- 75 mm thickness insulation
- Super silent performance based on the advanced noise decreasing technology
- Special structure design make super big inner volume
- Adjustable thermostat
- Main power indicator
- Defrost water drain hole
- Adjustable feet
- Environmentally friendly

Options

- Interior LED light/outside Condensor/ Caster wheels/ full baskets/digital thermometer



Product Model	BD/BC-160	BD/BC-190	BD/BC-220	BD/BC-240
Unit dimension (W/D/H mm)	935*560*825	935*560*890	1075*560*890	1172*560*890
Packing dimension (W/D/H mm)	985*655*885	985*655*955	1125*655*955	1225*655*955
Net capacity (L)	150	172	200	220
Cooling system	Static	Static	Static	Static
Climate	ST	ST	ST	ST
Temperature (°C)	BC : -2~5/ BD : -12~-25	BC : -2~5/ BD : -12~-25	BC : -2~5/ BD : -12~-25	BC : -2~5/ BD : -12~-25
Inner glass door	2	2	2	2
Kind of coolant	R134a/R600a	R134a/R600a	R134a/R600a	R134a/R600a
40'HC Container loading	126	108	100	77

LOW TEMPERATURE FREEZER



BD-470L

Features

- Korea temperature freezer
- 70mm thickness insulation
- Suitable for wide climate, SN/T
- Adjustable thermostat
- Main power indicator
- Defrost water drain hole
- External handle with lock
- Environmentally friendly
- Available in silver body color

Options

- outside Condensor/wheels/full baskets/digital thermometer/-35°C temperature



Product Model	BD-470L	BD-570L	BD-670L
Unit Dimension (W/D/H mm)	1130×755×840	1470×755×840	1810×755×840
Packing Dimension (W/D/H mm)	1190×770×890	1530×770×860	1870×770×860
Net capacity (L)	360L	460L	570L
Cooling system	Static	Static	Static
Foaming thickness (mm)	70	70	70
Climate	SN/T	SN/T	SN/T
Energy class	A+	A+	A+
Temperature (°C)	≤-20	≤-20	≤-20
Basket No.	1	1	1
Kind of coolant	R134a	R134a	R134a
40 'HC Container loading	90	66	56

LOW TEMPERATURE FREEZER



BD-690L

Features

- Korea temperature freezer
- 90mm thickness insulation
- Suitable for wide climate, SN/T
- Adjustable thermostat
- Main power indicator
- Defrost water drain hole
- External handle with lock
- Environmentally friendly
- Available in silver body color

Options

- outside Condensor/wheels/full baskets/digital thermometer/-45°C temperature



Product Model	BD-490L	BD-590L	BD-690L
Unit Dimension (W/D/H mm)	1130×755×840	1470×755×840	1810×755×840
Packing Dimension (W/D/H mm)	1190×770×890	1530×770×860	1870×770×860
Net capacity (L)	310L	400L	500L
Cooling system	Static	Static	Static
Foaming thickness (mm)	90	90	90
Climate	SN/T	SN/T	SN/T
Energy class	A+	A+	A+
Temperature (°C)	≤-25	≤-25	≤-25
Basket No.	1	1	1
Kind of coolant	R134a	R134a	R134a
40 'HC Container loading	90	66	56

FEET AND WHEEL



HANDLE



CONTROL PANEL



LINER&CONDENSER





NEUTRAL
EQUIPMENT

GASTRONORM PAN



DOUBLE (2/1) SIZE GN PAN
650*530mm
DEEP:20mm 40mm 65mm 100mm 150mm



FULL (1/1) SIZE GN PAN
530*325mm
DEEP:20mm 40mm 65mm 100mm 150mm 200mm



TWO THIRD (2/3) SIZE GN PAN
354*325mm
DEEP:20mm 40mm 65mm 100mm 150mm 200mm



ONE HALF (1/2) SIZE GN PAN
325*265mm
DEEP:20mm 40mm 55mm 65mm 90mm 100mm
140mm 150mm 190mm 200mm

GASTRONORM PAN



ONE HALF LONG (2/4) SIZE GN PAN
530*162mm
DEEP:20mm 65mm 100mm 150mm



COVER



FULL (1/1) SIZE PERFORATED GN PAN
530*325mm
DEEP:20mm 40mm 55mm 65mm 90mm 100mm
140mm 150mm 190mm 200mm



ONE HALF (1/2) SIZE OERFIRATED GN PAN
325*265mm
DEEP:20mm 40mm 55mm 65mm 90mm 90mm
100mm 140mm 150mm 190mm 200mm



ONE THIRD (1/3) SIZE GN PAN
325*176mm
DEEP:20mm 40mm 65mm 100mm 150mm
200mm



ONE QUARTER (1/4) SIZE GN PAN
265*162mm
DEEP:20mm 65mm 100mm 150mm 200mm



ONE SIXTH (1/6) SIZE GN PAN
176*162mm
DEEP:35mm 65mm 100mm 150mm 200mm



ONE NINTH (1/9) SIZE GN PAN
176*108mm
DEEP:65mm 100mm 150mm

REGULAR PANS

SMOOTH CORNER DESIGN



CLEANING SURFACE WITH A LITTLE BIT INCLINED, EASY TO STACK UP AND SAVING THE SPACE

DOUBLE REINFORCED & EMBOSSED CORNERS



FULL (1/1) SIZE PAN
20-3/4" * 12-3/4" (530*325mm)
DEEP: 32mm 65mm 100mm 150mm 200mm



TWO THIRD (2/3) SIZE PAN
13-7/8" * 12-3/4" (354*325mm)
DEEP: 65mm 100mm 150mm 200mm



ONE HALF (1/2) SIZE PAN
12-3/4" * 10-3/8" (325*265mm)
DEEP: 32mm 65mm 100mm 150mm 200mm



ONE THIRD (1/3) SIZE PAN
12-3/4" * 6-7/8" (325*176mm)
DEEP: 65mm 100mm 150mm

REGULAR PANS



ONE QUARTER (1/4) SIZE PAN
10-3/8" * 6-3/8" (265*162mm)
DEEP: 65mm 100mm 150mm



ONE SIXTH (1/6) SIZE PAN
6-7/8" * 6-1/4" (176*162mm)
DEEP: 65mm 100mm



ONE NINTH (1/9) SIZE PAN
6-7/8" * 4-1/4" (176*108mm)
DEEP: 65mm 100mm



SOLID & SLOTTED COVER



1/1 SIZE PERFORATED PAN
20-3/4" * 12-3/4" (530*325mm)
DEEP: 32mm 65mm 100mm 150mm 200mm



1/2 SIZE PERFORATED PAN
12-3/4" * 10-3/8" (325*265mm)
DEEP: 32mm 65mm 100mm 150mm 200mm

MINI KITCHEN



TOP	Stainless steel			
Refrigerator	Embedded type(85L) (chiller+freezer)			
Hydrovalve	Apolegamy			
Bottom Bracket	Wood particle board	multilayer board		
Model	KE230M	KI120E	KR118M	KR230M
cooking range	Electrical Hob	Induction Cooker	Ceramic Hob	Ceramic Hob
Power	3000W	3000W	1800W	3000W
Dimensions	1000*890*600mm(W*H*D)			



TOP	Stainless steel			
Refrigerator	Embedded type(85L) (chiller+freezer)			
Hydrovalve	Apolegamy			
Bottom Bracket	Wood particle board	multilayer board		
Model	KE230M	KI120E	KR118M	KR230M
cooking range	Electrical Hob	Induction Cooker	Ceramic Hob	Ceramic Hob
Power	3000W	2000W	1800W	3000W
Dimensions	1000*890*600mm(W*H*D)			

MINI KITCHEN



TOP	Stainless steel			
Refrigerator	Embedded type(85L) (chiller+freezer)			
Hydrovalve	Apolegamy			
Bottom Bracket	Wood particle board	multilayer board		
Model	KE230M	KI120E	KR118M	KR230M
cooking range	Electrical Hob	Induction Cooker	Ceramic Hob	Ceramic Hob
Power	3000W	2000W	1800W	3000W
TOP	Stainless steel			
Refrigerator	Embedded type(85L) (chiller+freezer)			
Dimensions	1000*890*600mm(W*H*D)			
Condole ark	1000*600*320mm(W*H*D)			



TOP	Stainless steel			
Refrigerator	Embedded type(85L) (chiller+freezer)			
Hydrovalve	Apolegamy			
Bottom Bracket	Wood particle board	multilayer board		
Model	KE230M	KI120E	KR118M	KR230M
cooking range	Electrical Hob	Induction Cooker	Ceramic Hob	Ceramic Hob
Power	3000W	2000W	1800W	3000W
TOP	Stainless steel			
Refrigerator	Embedded type(85L) (chiller+freezer)			
Dimensions	1000*890*600mm(W*H*D)			
Condole ark	1000*600*320mm(W*H*D)			

WORK TABLE



MODEL NO.	DIMENSION(W*D*H)MM
WT86	800*600*850
WT106	1000*600*850
WT126	1200*600*850
WT146	1400*600*850
WT166	1600*600*850
WT186	1800*600*850
WT206	2000*600*850



MODEL NO.	DIMENSION(W*D*H)MM
WT87	800*700*850
WT107	1000*700*850
WT127	1200*700*850
WT147	1400*700*850
WT167	1600*700*850
WT187	1800*700*850
WT207	2000*700*850

CUPBOARD



MODEL NO.	DIMENSION(W*D*H)MM
CR66	600X600X850
CR86	800X600X850
CR106	1000X600X850
CR126	1200X600X850
CR146	1400X600X850
CR156	1500X600X850
CR166	1600X600X850
CR186	1800X600X850
CR206	2000X600X850



MODEL NO.	DIMENSION(W*D*H)MM
CR67	600X700X850
CR87	800X700X850
CR107	1000X700X850
CR127	1200X700X850
CR147	1400X700X850
CR157	1500X700X850
CR167	1600X700X850
CR187	1800X700X850
CR207	2000X700X850

SERVING TROLLEY



SERVING TROLLEY WITH 1 SHELF

MODEL NO.	DIMENSION(W*D*H)MM
ST106	1000*600*850

SERVING TROLLEY WITH 2 SHELVES

MODEL NO.	DIMENSION(W*D*H)MM
ST85-2	800*500*940
ST105-2	1000*500*940
ST106-2	1000*600*940
ST126-2	1200*600*940



SERVING TROLLEY WITH 3 SHELVES

MODEL NO.	DIMENSION(W*D*H)MM
ST85-3	800*500*940
ST105-3	1000*500*940
ST106-3	1000*600*940
ST126-3	1200*600*940

WALL SHELVES



MODEL NO.	DIMENSION(W*D*H)MM
STS1340	1300*400*1800
STS1350	1300*500*1800
STS1360	1300*600*1800
STS1440	1400*400*1800
STS1450	1400*500*1800
STS1460	1400*600*1800
STS1540	1500*400*1800
STS1550	1500*500*1800
STS1560	1500*600*1800
STS1640	1600*400*1800
STS1650	1600*500*1800
STS1660	1600*600*1800
STS1740	1700*400*1800
STS1750	1700*500*1800
STS1760	1700*600*1800
STS1840	1800*400*1800
STS1850	1800*500*1800
STS1860	1800*600*1800
STS1940	1900*400*1800
STS1950	1900*500*1800
STS1960	1900*600*1800
STS2040	2000*400*1800
STS2050	2000*500*1800
STS2060	2000*600*1800

MODEL NO.	DIMENSION(W*D*H)MM
STS640	600*400*1800
STS650	600*500*1800
STS660	600*600*1800
STS740	700*400*1800
STS750	700*500*1800
STS760	700*600*1800
STS840	800*400*1800
STS850	800*500*1800
STS860	800*600*1800
STS940	900*400*1800
STS950	900*500*1800
STS960	900*600*1800
STS1040	1000*400*1800
STS1050	1000*500*1800
STS1060	1000*600*1800
STS1140	1100*400*1800
STS1150	1100*500*1800
STS1160	1100*600*1800
STS1240	1200*400*1800
STS1250	1200*500*1800
STS1260	1200*600*1800



SINK

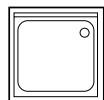
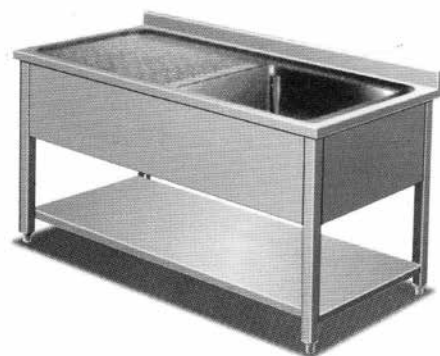

MODES	DIM.MM	DIM OF SINK
STR 66 BM1	600*600*950h	400*400*250h/300h
STR 76 BM1	700*600*950h	500*400*250h/300h
STR 86 BM1	800*600*950h	500*400*250h/300h

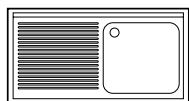

MODES	DIM.MM	DIM OF SINK
STR 106 BR1	1000*600*950h	400*400*250h/300h
STR 126 BR1	1200*600*950h	500*400*250h/300h

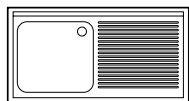

MODES	DIM.MM	DIM OF SINK
STR 106 BL1	1000*600*950h	400*400*250h/300h
STR 126 BL1	1200*600*950h	500*400*250h/300h

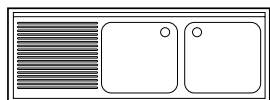

MODES	DIM.MM	DIM OF SINK
STR 146 BR2	1400*600*950h	400*400*250h/300h
STR 166 BR2	1600*600*950h	500*400*250h/300h
STR 186 BR2	1800*600*950h	500*400*250h/300h

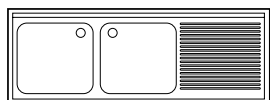

MODES	DIM.MM	DIM OF SINK
STR 146 BL2	1400*600*950h	400*400*250h/300h
STR 166 BL2	1600*600*950h	500*400*250h/300h
STR 186 BL2	1800*600*950h	500*400*250h/300h

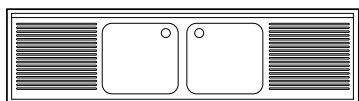

MODES	DIM.MM	DIM OF SINK
STR 206 BM2	2000*600*950h	500*400*250h/300h

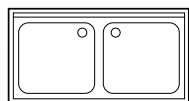

MODES	DIM.MM	DIM OF SINK
STR 106 BM2	1000*600*950h	400*400*250h/300h
STR 126 BM2	1200*600*950h	500*400*250h/300h
STR 146 BM2	1400*600*950h	500*400*250h/300h

MODES	DIM.MM	DIM OF SINK
STR 67 BM1	600*700*950h	500*400*250h/300h
STR 77 BM1	700*700*950h	600*500*250h/300h
STR 87 BM1	800*700*950h	600*500*250h/300h

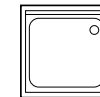

MODES	DIM.MM	DIM OF SINK
STR 107 BR1	1000*700*950h	500*400*250h/300h
STR 127 BR1	1200*700*950h	500*500*250h/300h
STR 147 BR1	1400*700*950h	600*500*250h/300h

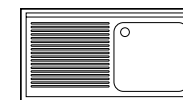

MODES	DIM.MM	DIM OF SINK
STR 107 BL1	1000*700*950h	500*400*250h/300h
STR 127 BL1	1200*700*950h	500*500*250h/300h
STR 147 BL1	1400*700*950h	600*500*250h/300h

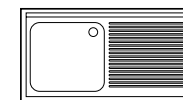

MODES	DIM.MM	DIM OF SINK
STR 167 BR2	1600*700*950h	500*400*250h/300h
STR 187 BR2	1800*700*950h	500*500*250h/300h

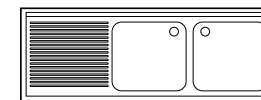

MODES	DIM.MM	DIM OF SINK
STR 167 BL2	1600*700*950h	500*400*250h/300h
STR 187 BL2	1800*700*950h	500*500*250h/300h

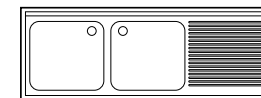

MODES	DIM.MM	DIM OF SINK
STR 207 BM2	2000*700*950h	500*400*250h/300h

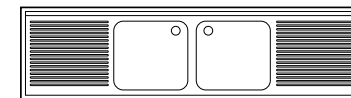

MODES	DIM.MM	DIM OF SINK
STR 107 BM2	1000*700*950h	500*400*250h/300h
STR 127 BM2	1200*700*950h	500*500*250h/300h
STR 147 BM2	1400*700*950h	600*500*250h/300h

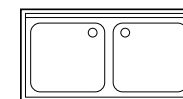

MODES	DIM.MM	DIM OF SINK
STR 127 BM1	1200*700*950h	1060*500*250h/300h
STR 167 BM1	1600*700*950h	1360*500*250h/300h
STR 187 BM1	1800*700*950h	1660*500*250h/300h

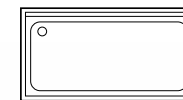

MODES	DIM.MM	DIM OF SINK
STR 207 BMB1	2000*700*950h	860*500*250h/300h

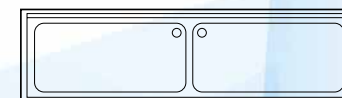



QINGDAO SANTA INTERNATIONAL CO.,LTD

Add1:No.25 Haihe Road,Jimo county,Qingdao City,
Shandong Province,P.R.China

Add2:Room 301 Building C Platinum Plaza, NO.5, Wenling Road,
Laoshan District,Qingdao,Shandong, China

Tel:0086-532-89067735

Email:info@santagroup.com.cn

Website:www.santagroup.com.cn

